

REVISION FOR DWG # 1PB-2LHB

REV	CH.NO.	DESCRIPTION	DATE	REVISED BY
-	-	ORIGINAL DESIGN	11/15/2007	PHILIPP E.

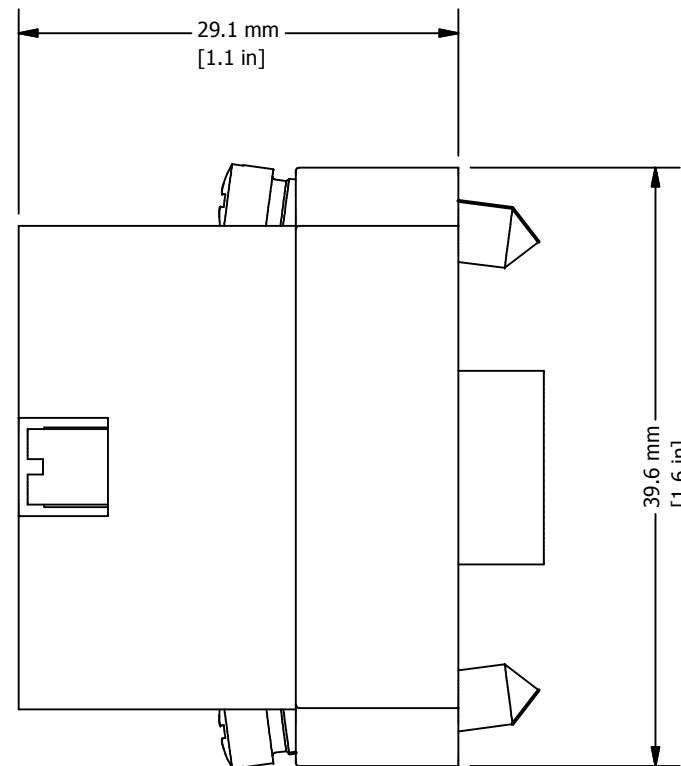

UNLESS OTHERWISE SPECIFIED:
 • ALL DIMENSIONS ARE IN MILLIMETERS
 • THIRD ANGLE PROJECTION

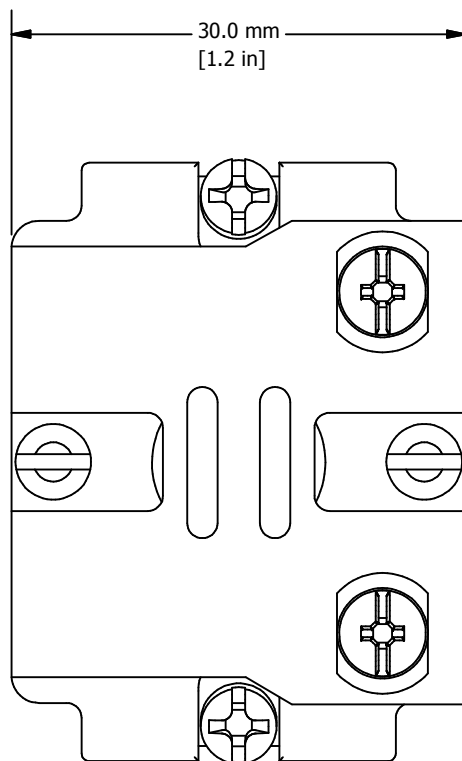
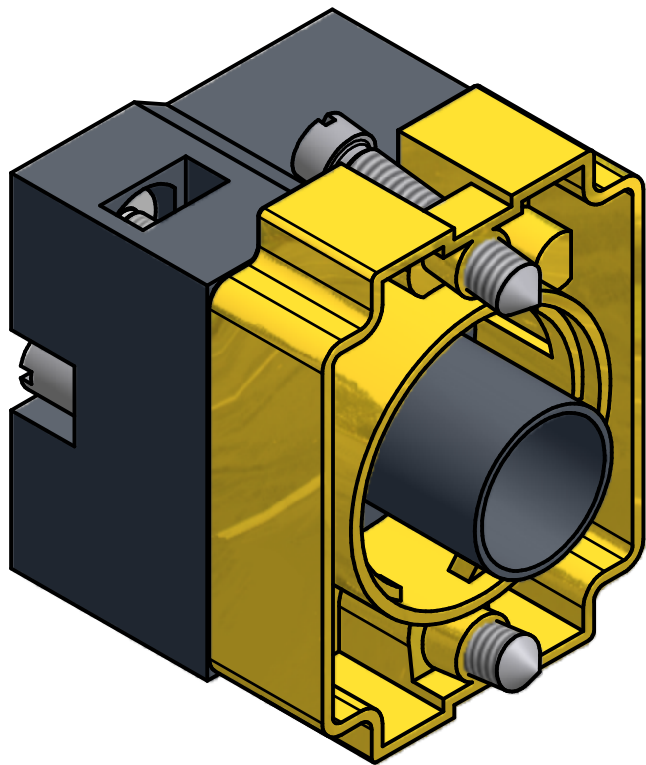

This Drawing is the property of

Altrech Corp.

35 Royal Road
 Flemington, NJ 08822-6000
 (908) 806-9400
 Fax (908) 806-9490

AND IS A CONFIDENTIAL DISCLOSURE LENT WITHOUT CONSIDERATION OTHER THAN THE BORROWER'S AGREEMENT THAT IT SHALL NOT BE REPRODUCED, COPIED, LENT OR DISPOSED OF DIRECTLY OR INDIRECTLY NOR USED FOR ANY PURPOSE OTHER THAN THAT FOR WHICH IT IS SPECIFICALLY FURNISHED.

TITEL **Bulb holder for illuminated Push buttons 2LHB**

TOLERANCE	
XX	= ±1 mm
XX.X	= ±0.5 mm
XX.XX	= ±0.2 mm
ALL	= - mm

M
E
T
R
I
C

DRAWN BY: Philipp Ernstberger	11/15/2007	DRAWING NO.:	REV.:
CHECKED BY: Laszlo Gyorgypal	11/15/2007	1PB-2LHB	1
RELEASED BY: Laszlo Gyorgypal	11/15/2007	SCALE: -	SHEET: - OF: -