

Altech Corp.®

Serving the Automation & Control Industry since 1984



Digital Panel Meters

Altech Corp.®

Since 1984, Altech Corporation has grown to become a leading supplier of automation and industrial control components. Headquartered in Flemington, NJ, Altech has an experienced staff of engineering, manufacturing and sales personnel to provide the highest quality products with superior service. This is the Altech Commitment!

With experienced Product Engineers and Customer Service personnel, Altech provides solutions to your most pressing application challenges. All with one thought in mind - *to ensure that we solve your problem the first time!*

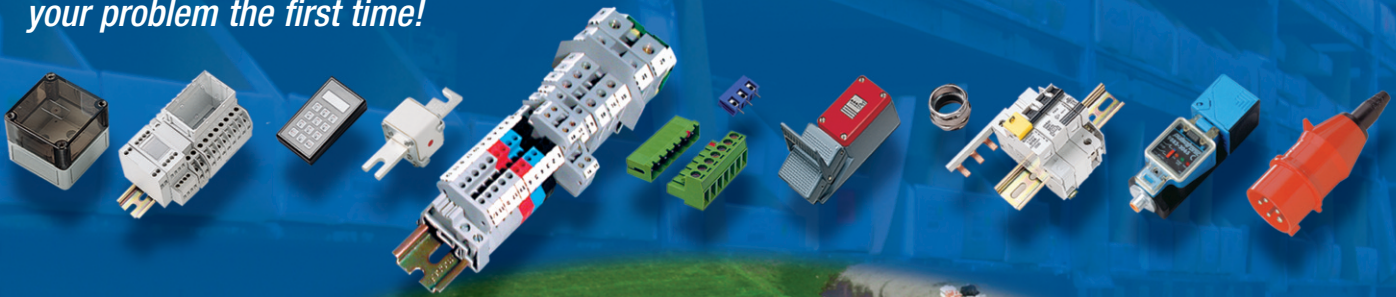

Quality Commitment

Altech's control components meet diverse national and international standards such as UL, NEC, CSA, IEC, VDE and more. Altech provides superior customer service and delivery through Total Quality Management and Continuous Process Improvement. Altech is ISO 9001 approved. We perform these services with honesty and integrity and are committed to achieve these goals.



Table of contents

Altech Digital Panel Meters

Features and Selection Guide	4-5
Digital Multi Function Meters	
MFM Series (Power, Energy, Voltage, Current, Frequency, Power Factor).....	6-7
VAF Series (Voltage, Current, Frequency)	8
EM Series (Power, Energy)	9
Digital Ampere Meters	
MA12 Series (LED Display).....	10
MA Series (LCD Display)	11
Digital Voltage Meters	
MV15 Series (LED Series).....	12
MV Series (LCD Display).....	13
Digital Frequency Meter	
MF16 Series.....	14
Digital Power Factor Meter	
MP14 Series	14
Disconnect and Test Terminal Block	
For Meter Circuits	15-17
Application Examples	16-17
Glossary	18-21
Index	22
Terms and Conditions	23

Digital Panel Meter Features

RS485 MODBUS
Communication
(available in MFM,
VAF and EM Series)

Pulse Output
(24VDC, 100mA)

UL Listed



MFM374-C-CU sample meter.

Faceplate;
IP65 Protection Rating

7 Segment
LED Display

Available Functions;
Voltage, Current,
Power, Energy,
Frequency and
Power Factor
(true RMS values)

Standard DIN sizes (1/4 DIN, 1/8 DIN and 1/16 DIN)

RS485 MODBUS
Communication
(available in MFM,
VAF and EM Series)

Pulse Output
(24VDC, 100mA)

Analog Bar Graph Indicator
for Current Percentage

UL Listed



MFM384-C-CU sample meter.

Faceplate;
IP65 Protection Rating

Modern
LCD Display

Available Functions;
Voltage, Current,
Power, Energy,
Frequency and
Power Factor
(true RMS values)

PART NUMBER	Supply Voltage		Phases		Functions						Display			Pulse Output	RS485 MODBUS Communication	PAGE
	110VAC	85-270VAC	1 Phase	3 Phase	Voltage	Current	Power Factor	Power	Frequency	Energy	LED	LCD	Bar Graph			
MFM384-C-CU		✓		✓	✓	✓	✓	✓	✓	✓		✓	✓	✓	✓	6
MFM383A-CU		✓		✓	✓	✓	✓	✓	✓	✓		✓		✓		6
MFM374-CU		✓		✓	✓	✓	✓	✓	✓	✓	✓			✓		7
MFM374-C-CU		✓		✓	✓	✓	✓	✓	✓	✓	✓			✓	✓	7
VAF36A-110V-CU	✓			✓	✓	✓			✓			✓	✓			8
VAF39A-110V-CU	✓			✓	✓	✓			✓		✓					8
EM368-C-CU		✓		✓			✓	✓		✓		✓		✓	✓	9
MA12-110V-CU	✓		✓			✓					✓					10
MA12-50mV-DC-110V-CU	✓		✓			✓					✓					10
MA12-100mV-DC-110V-CU	✓		✓			✓					✓					10
MA501-110V-CU	✓		✓			✓						✓	✓			11
MA2301-110V-CU	✓			✓		✓						✓	✓			11
MV15-110V-CU	✓		✓		✓						✓					12
MV15-DC-20V-110V-CU	✓		✓		✓						✓					12
MV15-DC-200V-110V-CU	✓		✓		✓						✓					12
MV507-110V-CU	✓		✓		✓							✓	✓			13
MV2307-110V-CU	✓			✓	✓							✓	✓			13
MF16-110V-CU	✓		✓						✓		✓					14
MP14-110V-CU	✓		✓				✓				✓					14

MFM Series (Multi-Function Meters)

FEATURES

- Measurement Functions
 - 3 Ø Voltage (True RMS)
 - 3 Ø Current (True RMS)
 - 3 Ø Power Factor
 - 3 Ø Power (Active, Reactive, Apparent)
 - Energy (Active, Reactive, Apparent)
 - Frequency
- Programmable CT/ PT Primary/ Secondary
- RS485 Modbus RTU Communication
- Single Pulse Output



CAT. NO.

MFM384-C-CU

MFM383A-CU

Display	MFM384-C-CU	MFM383A-CU
Display Type	LCD Display with backlight	LCD Display with backlight
Digits	4 rows of 4 digits 1 row of 8 digits for energy display	3 rows of 4 digits 1 row of 7.5 digits for energy display
Bargraph	Bargraph for current percentage	-
Display Scrolling	Automatic/ Manual	Automatic/ Manual
Supply Specification	85 ~ 270 VAC (50/ 60Hz)	85 ~ 270 VAC (50/ 60Hz)
Input Specification		
Electrical Wire System	3 Phase (3/4 wires), 2 Phase (3 wire), 1 Phase (2 wire)	3 Phase (3/4 wires), 2 Phase (3 wire), 1 Phase (2 wire)
Input Voltage Range	11 ~ 300 VAC (Phase to Neutral) 19 ~ 519 VAC (Phase to Phase)	11 ~ 300 VAC (Phase to Neutral) 19 ~ 519 VAC (Phase to Phase)
Input Current Range	10mA ~ 5A (External CT required for current >5A)	10mA ~ 5A (External CT required for current >5A)
Frequency	45 ~ 65Hz	45 ~ 65Hz
Parameter Resolution		
Energy	0.01k, 0.1k, 1k, 0.01M, 0.1M, 1M	0.01k, 0.1k, 1k depending on CT ratio x PT ratio
Power, Voltage, Current	Auto resolution	Auto resolution
Power Factor	0.001	0.001
Accuracy Class		
Voltage (L-N, L-L), Current	+/- 0.5% of Full-Scale Value	+/- 0.5% of Full-Scale Value
Power Factor	+/-1%	+/-1%
Frequency	0.1 Hz +/- 0.1 Hz	0.1 Hz +/- 0.1 Hz
Active, Reactive, Apparent Power	1%	1%
Active, Reactive, Apparent Energy	Class 1	Class 1
Output Specifications		
Pulse Output	1	1
Pulse Voltage	24 VDC max.	24 VDC max.
Pulse Current	100mA max.	100mA max.
Pulse Duration	100ms +/-5ms	100ms +/-5ms
Communication	RS485 MODBUS Communication	-
Programmable Parameters		
CT Primary	1A/ 5A ~ 10,000A (Programmable for any value)	1A/ 5A ~ 10,000A (Programmable for any value)
CT Secondary	1A/ 5A (External CT must be connected for current >5A)	1A/ 5A (External CT must be connected for current >5A)
PT Primary	100V ~ 500 kV (any value)	100V ~ 10 kV (any value)
PT Secondary	100V ~ 500 VAC (any value)	100V ~ 500 VAC (any value)
Environmental Specifications		
Temperature	Operating: -10°C~55°C, Storage: -20°C~ 75°C	Operating: -10°C~55°C, Storage: -20°C~ 75°C
Humidity	Up to 85% RH	Up to 85% RH
Protection Level	IP65 for Faceplate	IP65 for Faceplate
Physical Specifications		
Size	1/4 DIN, 96 mm x 96 mm	1/4 DIN, 96 mm x 96 mm
Weight	0.70 lbs (318g)	0.70 lbs (318g)
Terminal Size Acceptability and Torque	20-14 AWG (0.5 - 2.5mm ²), 6-7 lb-in. (0.68 - 0.79Nm)	20-14 AWG (0.5 - 2.5mm ²), 6-7 lb-in. (0.68 - 0.79Nm)

DIMENSIONS

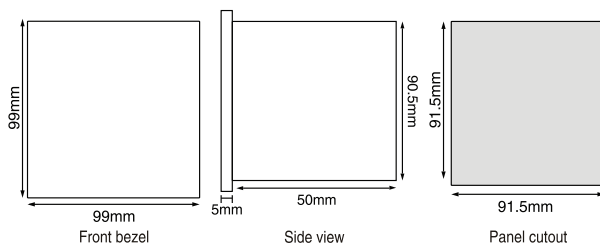

MFM Series

TERMINAL CONNECTIONS

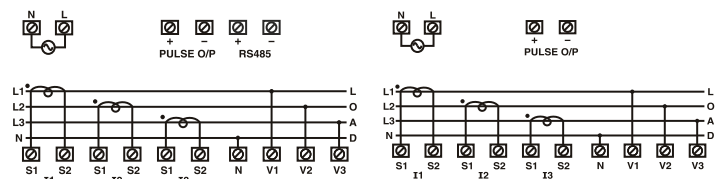

MFM384-C-CU

MFM383A-CU

FEATURES

- Measurement Functions
 - 3 Ø Voltage (True RMS)
 - 3 Ø Current (True RMS)
 - 3 Ø Power Factor
 - 3 Ø Power (Active, Reactive, Apparent)
 - Energy (Active, Reactive, Apparent)
 - Frequency
- Programmable CT/ PT Primary/ Secondary
- RS485 Modbus RTU Communication
- Single Pulse Output



Please contact Altech for UL status.



CAT. NO.	MFM374-C-CU	MFM374-A-CU
Display		
Display Type	7 Segment LED Display	7 Segment LED Display
Digits	3 rows of 4 digits 8 digits for energy display	3 rows of 4 digits 8 digits for energy display
Bargraph	—	—
Display Scrolling	Automatic/ Manual	Automatic/ Manual
Supply Specification	85 ~ 270 VAC (50/ 60Hz)	85 ~ 270 VAC (50/ 60Hz)
Input Specification		
Electrical Wire System	3 Phase (3/4 wires), 2 Phase (3 wire), 1 Phase (2 wire)	3 Phase (3/4 wires), 2 Phase (3 wire), 1 Phase (2 wire)
Input Voltage Range	11 ~ 300 VAC (Phase to Neutral) 19 ~ 519 VAC (Phase to Phase)	11 ~ 300 VAC (Phase to Neutral) 19 ~ 519 VAC (Phase to Phase)
Input Current Range	10mA ~ 5A (External CT required for current >5A)	10mA ~ 5A (External CT required for current >5A)
Frequency	45 ~ 65Hz	
Parameter Resolution		
Energy	0.01k, 0.1k, 1k, 0.01M, 0.1M, 1M	0.01k, 0.1k, 1k, 0.01M, 0.1M, 1M
Power, Voltage, Current	Auto resolution	Auto resolution
Power Factor	0.001	0.001
Accuracy Class		
Voltage (L-N, L-L), Current	+/- 0.5% of Full-Scale Value	+/- 0.5% of Full-Scale Value
Power Factor	+/-1%	+/-1%
Frequency	0.1 Hz	0.1 Hz
Active, Reactive, Apparent Power	1%	1%
Active, Reactive, Apparent Energy	Class 1	Class 1
Output Specifications		
Pulse Output	1	1
Pulse Voltage	24 VDC max.	24 VDC max.
Pulse Current	100mA max.	100mA max.
Pulse Duration	100ms +/-5ms	100ms +/-5ms
Communication	RS485 MODBUS Communication	—
Programmable Parameters		
CT Primary	1A/ 5A ~ 10,000A (Programmable for any value)	1A/ 5A ~ 10,000A (Programmable for any value)
CT Secondary	1A/ 5A (External CT must be connected for current >5A)	1A/ 5A (External CT must be connected for current >5A)
PT Primary	100V ~ 500 kV (any value)	100V ~ 10 kV (any value)
PT Secondary	100V ~ 500 VAC (any value)	100V ~ 500 VAC (any value)
Environmental Specifications		
Temperature	Operating: -10°C~55°C, Storage: -20°C~ 75°C	Operating: -10°C~55°C, Storage: -20°C~ 75°C
Humidity	Up to 85% RH	Up to 85% RH
Protection Level	IP65 for Faceplate	IP65 for Faceplate
Physical Specifications		
Size	1/4 DIN, 96 mm x 96 mm	1/4 DIN, 96 mm x 96 mm
Weight	0.71 lbs (320g)	0.71 lbs (320g)
Terminal Size Acceptability and Torque	20-14 AWG (0.5 - 2.5mm ²), 6-7 lb-in. (0.68 - 0.79Nm)	20-14 AWG (0.5 - 2.5mm ²), 6-7 lb-in. (0.68 - 0.79Nm)

DIMENSIONS

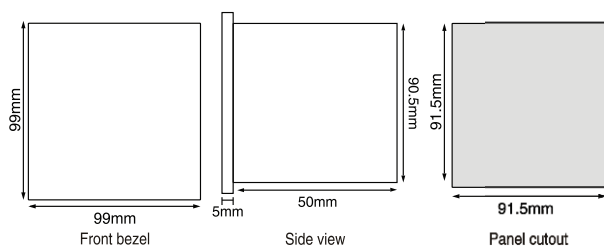

MFM Series

TERMINAL CONNECTIONS

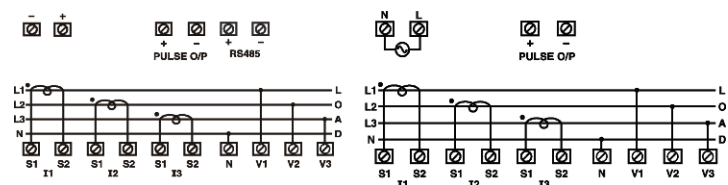

MFM374-C-CU

MFM374A-CU

VAF Series (Volt-Ampere-Frequency Meters)

FEATURES

- Measurement Functions
 - 3 Ø Voltage (True RMS)
 - 3 Ø Current (True RMS)
- Frequency
- RPM
- Run Hour
- Programmable CT Primary, PT Primary/Secondary



CAT. NO.

VAF36A-110V-CU

VAF39A-110V-CU

Display		
Display Type	LCD Display with backlight	7 Segment LED Display
Digits	3 rows of 3 digits	3 rows of 3 digits
Bargraph	Bargraph for current percentage	-
Display Scrolling	Automatic/ Manual	Automatic/ Manual
Supply Specification	110 VAC +/- 20% (50/60Hz)	110 VAC +/- 20% (50/60Hz)
Input Specification		
Electrical Wire System	3 Phase (3/4 wires)	3 Phase (3/4 wires)
Input Voltage Range	11 ~ 300 VAC (Phase to Neutral) 19 ~ 519 VAC (Phase to Phase)	11 ~ 300 VAC (Phase to Neutral) 19 ~ 519 VAC (Phase to Phase)
Input Current Range	20mA ~ 6A (External CT required for current >5A)	20mA ~ 6A (External CT required for current >5A)
Frequency	45 ~ 65Hz	45 ~ 65Hz
Parameter Resolution		
Current	0.01, 0.1, 1 A/KA	0.01, 0.1, 1 A/KA
Voltage	0.1 V/KV	0.1 V/KV
RPM	0.1	0.1
Run Hour	0.1 hr (0~99999.9 hr)	0.1 hr (0~99999.9 hr)
Accuracy Class		
Voltage (L-N, L-L), Current	+/- 0.5% of Full-Scale Value, +/- 2 digits	+/- 0.5% of Full-Scale Value, +/- 2 digits
Average Voltage (L-N, L-L), Current	+/-0.5% of Full-Scale Value, +/- 2 digits	+/-0.5% of Full-Scale Value, +/- 2 digits
Frequency	0.1 Hz	0.1 Hz
RPM	+/- 0.5%	+/- 0.5%
Run Hour	+/- 1%	+/- 1%
Output Specifications		
Pulse Output	-	-
Communication		
	-	-
Programmable Parameters		
CT Primary	5A ~ 10,000A (Programmable for any value)	5A ~ 10,000A (Programmable for any value)
CT Secondary	5A fixed (External CT must be connected for current >5A)	5A fixed (External CT must be connected for current >5A)
PT Primary	100V ~ 500 kV (any value)	100V ~ 500 kV (any value)
PT Secondary	100V ~ 500 VAC (any value)	100V ~ 500 VAC (any value)
Environmental Specifications		
Temperature	Operating: -10°C~55°C, Storage: -20°C~ 75°C	Operating: -10°C~55°C, Storage: -20°C~ 75°C
Humidity	Up to 85% RH	Up to 85% RH
Protection Level	IP65 for Faceplate	IP65 for Faceplate
Physical Specifications		
Size	1/4 DIN, 96 mm x 96 mm	1/8 DIN, 48 mm x 96 mm
Weight	0.79 lbs (357g)	0.79 lbs (357g)
Terminal Size Acceptability and Torque	20-14 AWG (0.5 - 2.5mm ²), 6-7 lb-in. (0.68 - 0.79Nm)	20-14 AWG (0.5 - 2.5mm ²), 6-7 lb-in. (0.68 - 0.79Nm)

DIMENSIONS

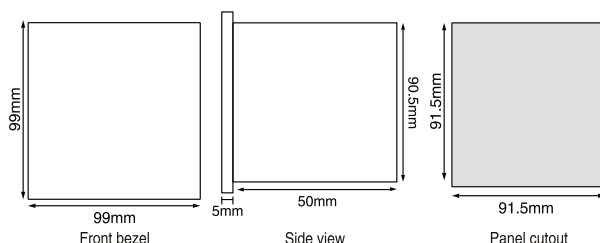

VAF Series

TERMINAL CONNECTIONS

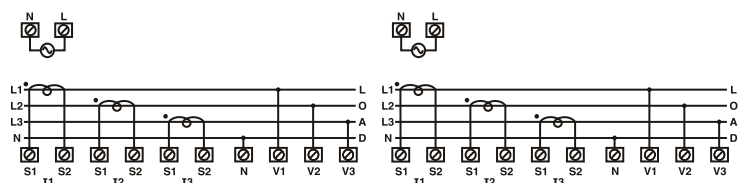

VAF36A-110V-CU

VAF39A-110V-CU

FEATURES

- Measurement Functions
 - **3 Ø Power (Active, Reactive, Apparent)**
 - **3 Ø Power Factor**
 - **Energy (Active, Reactive, Apparent)**
- Programmable CT Primary, PT Primary/Secondary
- RS485 Modbus RTU Communication
- Single Pulse Output



CAT. NO.

EM368-C-CU

Display	
Display Type	LCD Display with backlight
Digits	8 digits
Bargraph	—
Display Scrolling	Automatic
Supply Specification	85 ~ 270 VAC (50/ 60Hz)
Input Specification	
Electrical Wire System	3 Phase (3/4 wires)
Input Voltage Range	11 ~ 300 VAC (Phase to Neutral) 19 ~ 519 VAC (Phase to Phase)
Input Current Range	10mA ~ 5A (External CT required for current >5A)
Frequency	45 ~ 65Hz
Parameter Resolution	
Energy	0.01k, 0.1k, 1k, 0.01M, 0.1M, 1M, 10M
Power	Auto resolution
Power Factor	0.01
Accuracy Class	
Power Factor	+/-1%
Active, Reactive, Apparent Power	+/-1%
Active, Reactive, Apparent Energy	Class 1
Output Specifications	
Pulse Output	1
Pulse Voltage	24 VDC max.
Pulse Current	100mA max.
Pulse Duration	100ms +/-5ms
Communication	RS485 MODBUS Communication
Programmable Parameters	
CT Primary	1A/ 5A ~ 10,000A (Programmable for any value)
CT Secondary	1A/ 5A (External CT must be connected for current >5A)
PT Primary	100V ~ 500 kV (any value)
PT Secondary	100V ~ 500 VAC (any value)
Environmental Specifications	
Temperature	Operating: -10°C~55°C, Storage: -20°C~ 75°C
Humidity	Up to 85% RH
Protection Level	IP65 for Faceplate
Physical Specifications	
Size	1/4 DIN, 96 mm x 96 mm
Weight	0.69 lbs (312g)
Terminal Size Acceptability and Torque	20-14 AWG (0.5 - 2.5mm ²), 6-7 lb-in. (0.68 - 0.79Nm)

DIMENSIONS

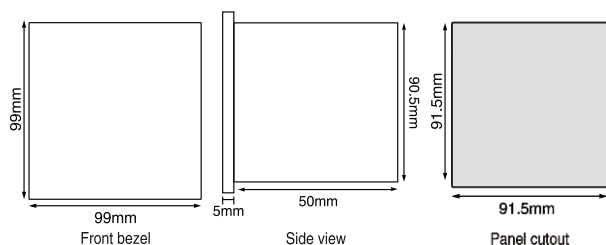

EM Series

TERMINAL CONNECTIONS

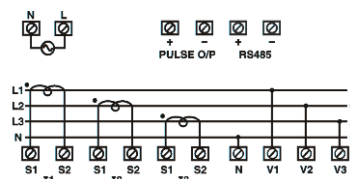

EM368-C

DIGITAL PANEL METERS

MA12 Series (LED Ampere Meters)

FEATURES

- Measurement Function
 - **1 Ø Current (True RMS)**
- Programmable CT Primary / Shunt Setting
- AC version (CT Type)
- DC version (Shunt Type, External Shunt (50mV/100mV) is required for measurement.)
- 4 Digit LED Display



CAT. NO.

MA12-110V-CU

MA12-50mV-DC-110V-CU MA12-100mV-DC-110V-CU

Display		
Display Type	7 segment LED display	7 segment LED display
Digits	4 digits	4 digits
Bargraph	-	-
Display Range	0 - 4960A	0 - 4960A
Supply Specification	110 VAC +/-20% (60Hz)	110 VAC +/-20% (60Hz)
Input Specification		
Electrical Wire System	1 Phase (2 wire)	1 Phase (2 wire)
Measurement Type	AC, CT Type (External CT required for current > 5A)	DC, Shunt Type (External shunt is required for current > 5A)
Shunt Size	-	50mV (MA12-50mV) 100mV (MA12-100mV)
Input Current Range	50mA ~ 5A (External CT required for current >5A)	50mA ~ 5A (External shunt required for current >5A)
Frequency Range	45 ~ 65Hz	45 ~ 65Hz
Parameter Resolution		
Current	0.001, 0.01, 0.1, 1A (depending on CT Primary)	0.001, 0.01, 0.1, 1A (depending on shunt setting)
Sampling Rate	3 samples / sec.	3 samples / sec.
Accuracy Class		
Current	+/- 0.5% of Full-Scale Value	+/- 0.5% of Full-Scale Value
Output Specifications		
Pulse Output	-	-
Communication		
	-	-
Programmable Parameters		
CT Primary / Shunt Setting	5, 10, 20, 30, 40, 50, 60, 75, 80, 100, 150, 200, 250, 300, 400, 500, 600, 800, 1000, 1200, 1500, 1600, 2000, 2500, 3000, 4000	5, 10, 20, 30, 40, 50, 60, 75, 80, 100, 150, 200, 250, 300, 400, 500, 600, 800, 1000, 1200, 1500, 1600, 2000, 2500, 3000, 4000
CT Secondary	5A fixed (External CT must be connected for current >5A)	-
Environmental Specifications		
Temperature	Operating: -10°C~55°C, Storage: -20°C~ 75°C	Operating: -10°C~55°C, Storage: -20°C~ 75°C
Humidity	Up to 85% RH	Up to 85% RH
Protection Level	IP65 for Faceplate	IP65 for Faceplate
Physical Specifications		
Size	1/8 DIN, 48 mm x 96 mm	1/8 DIN, 48 mm x 96 mm
Weight	0.37 lbs (170g)	0.37 lbs (170g)
Terminal Size Acceptability and Torque	20-14 AWG (0.5 - 2.5mm ²), 6-7 lb-in. (0.68 - 0.79Nm)	20-14 AWG (0.5 - 2.5mm ²), 6-7 lb-in. (0.68 - 0.79Nm)

DIMENSIONS

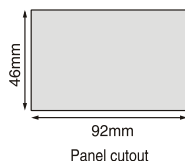
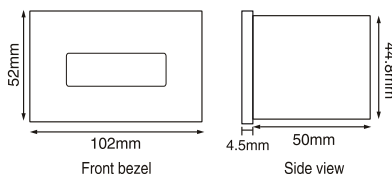

MA12 Series

TERMINAL CONNECTIONS



MA12-110V-CU (CT Type)



MA12-mV-DC-110V-CU (Shunt Type)

230 VAC versions also available, please consult Altech.

FEATURES

- Measurement Functions
 - 1 Ø Current (True RMS)
 - 3 Ø Current (True RMS)
- Integrated selector switch for phase selection (MA2301)
- LCD Display with Backlight
- Bargraph Indicator



CAT. NO.	MA501-110V-CU	MA2301-110V-CU
Display		
Display Type	LCD display with backlight	LCD display with backlight
Digits	4 digits	4 digits
Bargraph	Analog bargraph indicator	Analog bargraph indicator
Display Range	0 ~ 6200A	0 ~ 6200A
Display Scrolling	-	manual phase selector switch
Supply Specification	110 VAC +/-20% (60Hz)	85 ~ 270 VAC (50/ 60Hz)
Input Specification		
Electrical Wire System	1 Phase (2 wire)	3 Phase/4 wire
Measurement Type	AC, CT Type (External CT required for current > 5A)	AC, CT Type (External CT required for current > 5A)
Input Current Range	50mA ~ 5A (External CT required for current >5A)	50mA ~ 5A (External CT required for current >5A)
Frequency Range	45 ~ 65Hz	45 ~ 65Hz
Parameter Resolution		
Current	0.001, 0.01, 0.1, 1A (depending on CT Primary)	0.001, 0.01, 0.1, 1A (depending on CT Primary)
Sampling Rate	3 samples / sec.	3 samples / sec.
Accuracy Class		
Current	+/- 0.5% of Full-Scale Value	+/- 0.5% of Full-Scale Value
Output Specifications		
Pulse Output	-	-
Communication		
	-	-
Programmable Parameters		
CT Primary	5, 10, 20, 30, 40, 50, 60, 75, 80, 100, 125, 150, 200, 250, 300, 400, 500, 600, 800, 1000, 1200, 1500, 1600, 2000, 2250, 2500, 3000, 4000, 5000	5, 10, 20, 30, 40, 50, 60, 75, 80, 100, 125, 150, 200, 250, 300, 400, 500, 600, 800, 1000, 1200, 1500, 1600, 2000, 2250, 2500, 3000, 4000, 5000
CT Secondary	5A fixed (External CT must be connected for current >5A)	5A fixed (External CT must be connected for current >5A)
Environmental Specifications		
Temperature	Operating: -10°C~55°C, Storage: -20°C~ 75°C	Operating: -10°C~55°C, Storage: -20°C~ 75°C
Humidity	Up to 85% RH	Up to 85% RH
Protection Level	IP65 for Faceplate	IP65 for Faceplate
Physical Specifications		
Size	1/16 DIN, 48 mm x 48mm	72 mm x 72 mm
Weight	0.25 lbs (113g)	0.40 lbs (163g)
Terminal Size Acceptability and Torque	20-14 AWG (0.5 - 2.5mm ²), 6-7 lb-in. (0.68 - 0.79Nm)	20-14 AWG (0.5 - 2.5mm ²), 6-7 lb-in. (0.68 - 0.79Nm)

DIMENSIONS

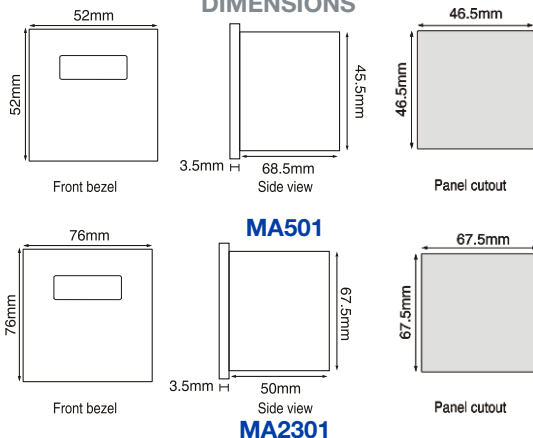

TERMINAL CONNECTIONS

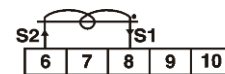

MA501-110V-CU

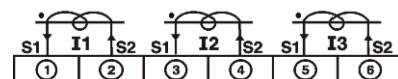
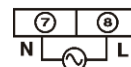

MA2301-110V-CU

230 VAC versions also available, please consult Altech.

MV15 Series (LED Voltage Meters)

FEATURES

- Measurement Function
 - 1 Ø Voltage (True RMS)
- 3 Digit LED Display



CAT. NO.

MV15-110V-CU

MV15-DC-20V-110V-CU MV15-DC-200V-110V-CU

CAT. NO.	MV15-110V-CU	MV15-DC-20V-110V-CU MV15-DC-200V-110V-CU
Display		
Display Type	7 segment LED Display	7 segment LED Display
Digits	3 digits	3 digits
Bargraph	–	–
Display Range	0 - 516V	0 - 516V
Supply Specification	110 VAC +/-20% (60Hz)	110 VAC +/-20% (60Hz)
Input Specification		
Electrical Wire System	1 Phase (2 wire)	1 Phase (2 wire)
Input Voltage Range	50 ~ 516 VAC	0 ~ 20 VDC (MV15-20V) 0 ~ 200 VDC (MV15-200V)
Frequency	50/60 Hz	50/60 Hz
Input Impedance	1 MΩ (+/-5%)	1 MΩ (+/-5%)
Parameter Resolution		
Voltage	1V	1V
Sample Rate	3 samples / sec.	3 samples / sec.
Accuracy Class		
Voltage	+/- 0.5% of Full-Scale Value	+/- 0.5% of Full-Scale Value
Output Specifications		
Pulse Output	–	–
Communication	–	–
Programmable Parameters	–	–
Environmental Specifications		
Temperature	Operating: -10°C~55°C, Storage: -20°C~ 75°C	Operating: -10°C~55°C, Storage: -20°C~ 75°C
Humidity	Up to 85% RH	Up to 85% RH
Protection Level	IP65 for Faceplate	IP65 for Faceplate
Physical Specifications		
Size	1/8 DIN, 48 mmx 96 mm	1/8 DIN, 48 mmx 96 mm
Weight	0.38 lbs (170g)	0.38 lbs (170g)
Terminal Size Acceptability and Torque	20-14 AWG (0.5 - 2.5mm ²), 6-7 lb-in. (0.68 - 0.79Nm)	20-14 AWG (0.5 - 2.5mm ²), 6-7 lb-in. (0.68 - 0.79Nm)

DIMENSIONS

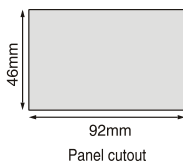
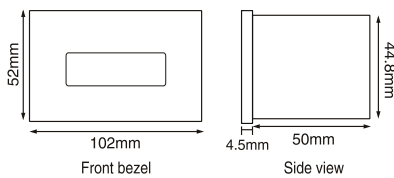

MV15 Series

TERMINAL CONNECTIONS



MV15-110V-CU (AC Type)



MV15-DC-20V-110V-CU (DC Type) MV15-DC-200V-110V-CU (DC Type)

230 VAC versions also available, please consult Altech.

FEATURES

- Measurement Functions
 - 1 Ø Voltage (True RMS)
 - 3 Ø Voltage (True RMS)
- Integrated selection switch for Phase Selection (MV2307)
- LCD Display with Backlight
- Bargraph Indicator



CAT. NO.

MV507-110V-CU

MV2307-110V-CU

Display	MV507-110V-CU	MV2307-110V-CU
Display Type	LCD display with backlight	LCD display with backlight
Digits	3 digits	3 digits
Bargraph	Analog style bargraph indicator	Analog style bargraph indicator
Display Range	0 - 516V	0 - 516V
Display Scrolling	-	manual phase selector switch
Supply Specification	110 VAC +/-20% (60Hz)	110 VAC +/-20% (60Hz)
Input Specification		
Electrical Wire System	1 Phase (2 wire)	3 Phase/4 wire
Input Voltage Range	50 ~ 516 VAC	50 ~ 516 VAC
Frequency	60 Hz	60 Hz
Input Impedance	1 MΩ (+/-5%)	1 MΩ (+/-5%)
Parameter Resolution		
Voltage	1V	1V
Sample Rate	3 samples / sec.	3 samples / sec.
Run Hour		
Accuracy Class		
Voltage	+/- 0.5% of Full-Scale Value	+/- 0.5% of Full-Scale Value
Output Specifications		
Pulse Output	-	-
Communication	-	-
Programmable Parameters	-	-
Environmental Specifications		
Temperature	Operating: -10°C~55°C, Storage: -20°C~ 75°C	Operating: -10°C~55°C, Storage: -20°C~ 75°C
Humidity	Up to 85% RH	Up to 85% RH
Protection Level	IP65 for Faceplate	IP65 for Faceplate
Physical Specifications		
Size	1/16 DIN, 48 mm x 48mm	72 mm x 72 mm
Weight	0.36 lbs (165g)	0.43 lbs (194g), 0.45 lbs (206g)
Terminal Size Acceptability and Torque	20-14 AWG (0.5 - 2.5mm ²), 6-7 lb-in. (0.68 - 0.79Nm)	20-14 AWG (0.5 - 2.5mm ²), 6-7 lb-in. (0.68 - 0.79Nm)

DIMENSIONS

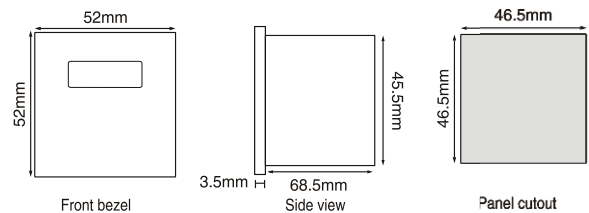

MV507

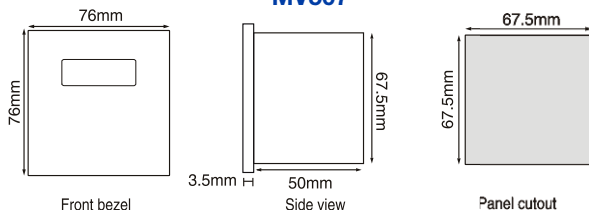

MV2307

TERMINAL CONNECTIONS

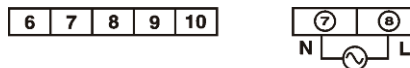

MV507

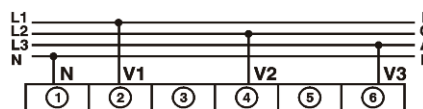

MV2307

230 VAC versions also available, please consult Altech.

MF16 Series (Frequency Meter) - MP14 Series (Power Factor Meter)

FEATURES

- Measurement Function
 - Frequency (MF16)
 - Power Factor (MP16)
- 4 Digit LED Display



CAT. NO.

MF16-110V-CU

MP14-110V-CU

Display		
Display Type	7 segment LED Display	7 segment LED Display
Digits	4 digits	4 digits
Bargraph	-	-
Display Range	45.00 ~ 65.00 Hz	-1.000 ~ +1.000
Supply Specification	110 VAC +/- 20% (60Hz)	110 VAC +/- 20% (60Hz)
Input Specification		
Electrical Wire System	1 Phase (2 wire)	1 Phase (2 wire)
Input Current Range	-	0.25 ~ 6A
Frequency Range	45 ~ 65 Hz	50/60Hz
Parameter Resolution		
Frequency	0.01 Hz	-
Power Factor	-	0.001
Accuracy Class		
Frequency	+/- 0.05Hz	-
Power Factor	-	+/- 0.05% +/- 2 digits
Output Specifications		
Pulse Output	-	-
Communication	-	-
Programmable Parameters	-	-
Environmental Specifications		
Temperature	Operating: -10°C~55°C, Storage: -20°C~ 75°C	Operating: -10°C~55°C, Storage: -20°C~ 75°C
Humidity	Up to 85% RH	Up to 85% RH
Protection Level	IP65 for Faceplate	IP65 for Faceplate
Physical Specifications		
Size	1/8 DIN, 48 mmx 96 mm	1/8 DIN, 48 mmx 96 mm
Weight	0.37 lbs (170g)	0.37 lbs (170g)
Terminal Size Acceptability and Torque	20-14 AWG (0.5 - 2.5mm ²), 6-7 lb-in. (0.68 - 0.79Nm)	20-14 AWG (0.5 - 2.5mm ²), 6-7 lb-in. (0.68 - 0.79Nm)

DIMENSIONS

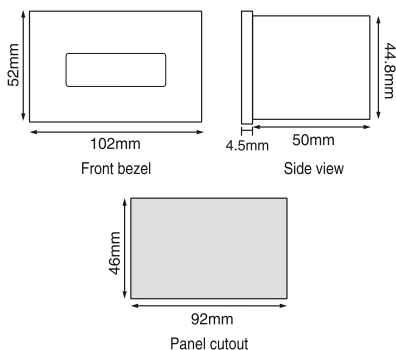

MF / MP Series

TERMINAL CONNECTIONS

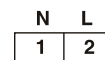

MF16-110V-CU

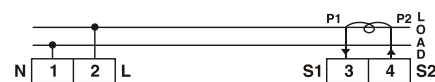

MP14-110V-CU

230 VAC versions also available, please consult Altech.

Disconnect and Test Terminal Blocks For Meter Circuits

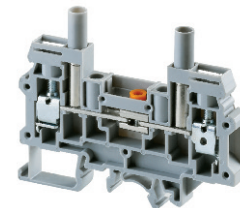
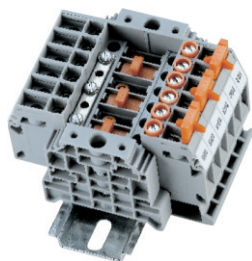

Disconnect and Test Terminals Blocks are an ideal choice for measuring control and regulatory circuits. The terminals provide a clear functional advantage for devices having utility instruments and associated transformers when it is mandatory to keep the secondary side shorted at any point while taking current measurements. Specially designed socket head screws act as test/monitoring points.

In the **CDS6U** separate testing points facilitate insertion of test probes. Disconnection is achieved by means of a slide link operated with a Screw Driver.

In the **CDS6U/TS**, the insulated test point screw system (**TPSLS**) is integrated.

The **SLS2** and **SLS4** slide shorting link can be used in combination with either the supplied screw or the **TPSLS** Test point screw system.

Lock out cap **LCCDS** can be used to lock the center shorting screw, to prevent accidental opening of circuits.

Specially designed socket head screws act as test/monitoring points in **CDTTU** and **CDTTU-SH**.

CDS6U

CDS6U/TS

Terminal Width	8 mm			8 mm		
Height x Length	50 x 82 mm			50 x 82 mm		
Stripping Length	10 mm			10 mm		
Insulation Material	Polyamide 6.6			Polyamide 6.6		
Type of Connection	2 screw clamps			2 screw clamps		
Approvals						
Wire Range	22-8 AWG	0.2-6 sq.mm	22-8 AWG	22-8 AWG	0.2-6 sq.mm	22-8 AWG
Voltage Rating	600 V	800 V	600 V	600 V	630 V	600 V
Current Rating	45 A	41 A	45 A	45 A	41 A	45 A
Torque	14 lb-in	0.8 Nm	14 lb-in	14 lb-in	0.8 Nm	14 lb-in
Other Approvals						
	Cat. No.	Std. Pk.	Cat. No.	Std. Pk.		
Terminal Block	CDS6U	50	CDS6U/TS	50		
End Plate	EPCDS6U	50	EPCDS6U	50		
DIN Rail for ordering info.						
End Stop	CA702 CA802	50 50	CA702 CA802	50 5		
Internal Jumper	2 pole 3 pole 4 pole 5 pole 10 pole	CA723/2 CA723/3 CA723/4 CA723/5 CA723/10	100 50 50 50 10	CA723/2 CA723/3 CA723/4 CA723/5 CA723/10	100 50 50 50 10	
Slide Shorting Link	2 pole 4 pole	SLS2 SLS4	50 25	SLS2 SLS4	50 25	
Insulated Test Socket	Gray Red Yellow Blue Black	TPSLS TPSLSR TPSLSY TPSLSBU TPSLSBK	100 100 100 100 100	TPSLSR TPSLSY TPSLSBU TPSLSBK	100 100 100 100	
Switchable Link Assembly		SWCDS	50	SWCDS	50	
Lock Out Cap		LCCDS	50	LCCDS	50	
Marking Tags		MT8	100	MT8	100	

Usage of Altech Disconnect & Test Terminal Block In Ampere Meter / Current Transformer Circuits

1 Phase

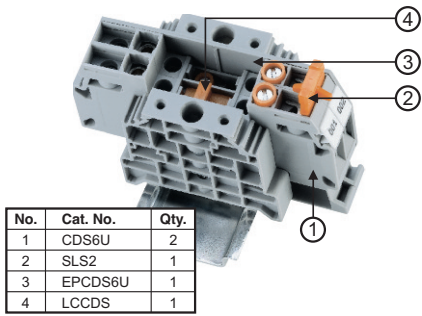

3 Phase (internal distribution of K-Point)

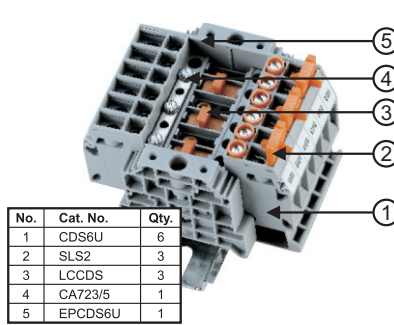

3 Phase (linked)

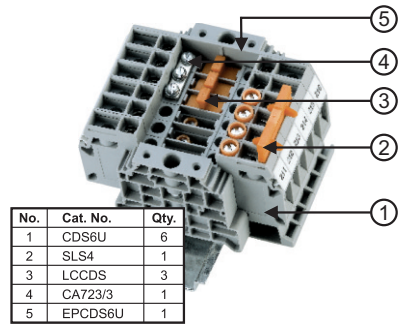

Operating status

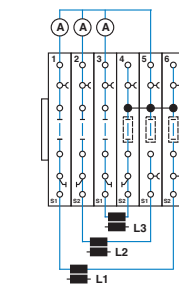
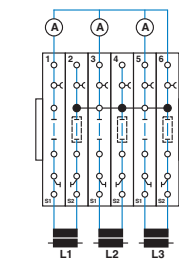
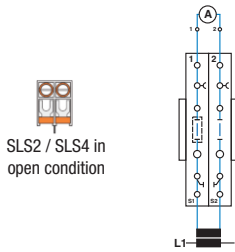

Comparison measurement for L1

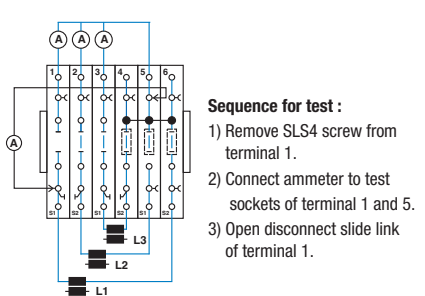
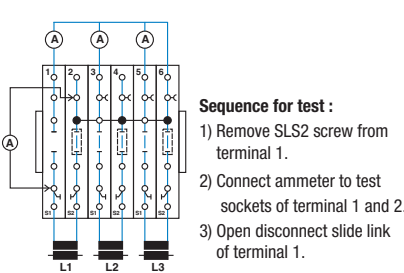
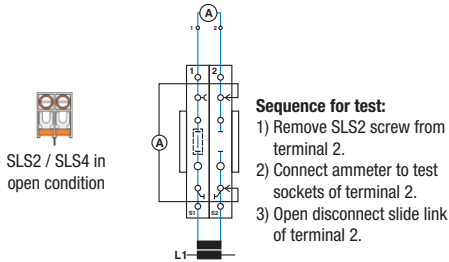

Meter test for L1 through external power supply

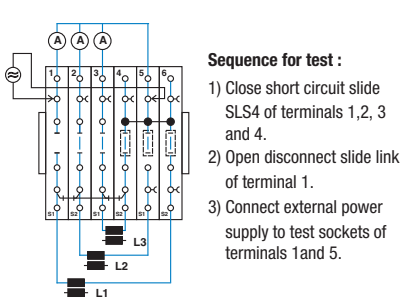
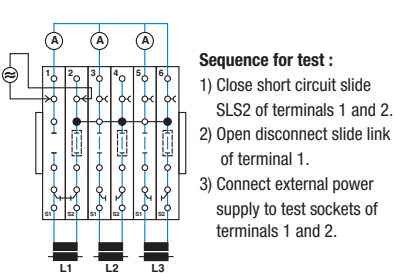
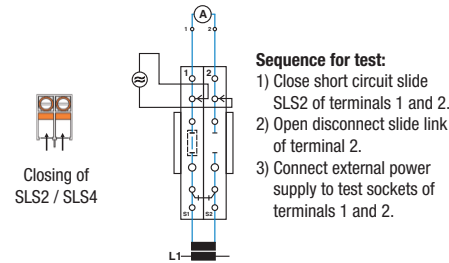

Meter Exchange for L1

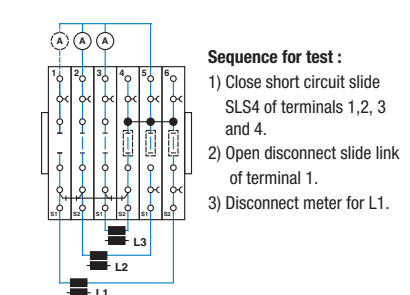
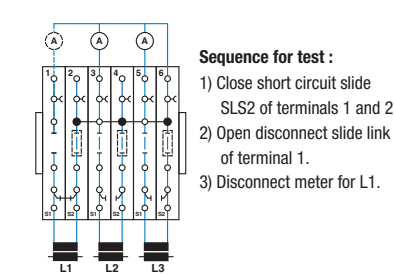
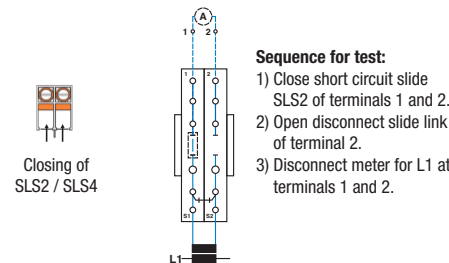

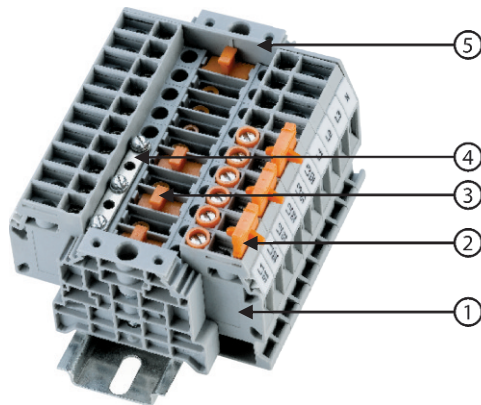

No.	Cat. No.	Qty.
1	CDS6U	10
2	SLS2	3
3	LCCDS	4
4	CA723/5	1
5	EPCDS6U	1

Operating status (with internal distribution of the k-point)

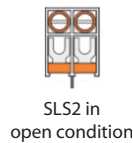
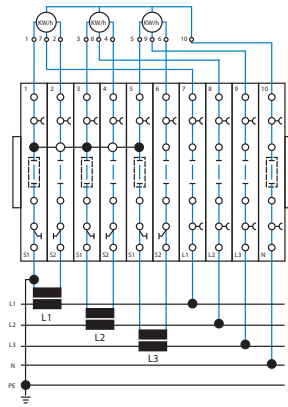

Meter test for L1 through external power supply

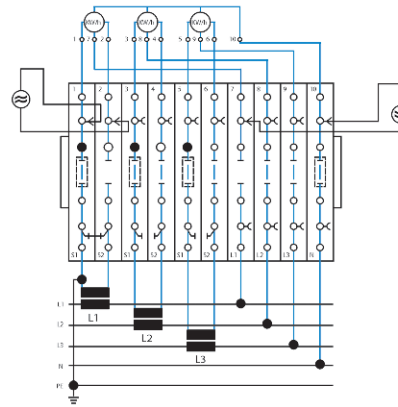

Sequence for test :

- 1) Close short circuit slide SLS2 of terminals 1 and 2.
- 2) Open disconnect slide link of terminal 2 and 7.
- 3) Connect external power supply to test sockets of terminals 1, 2 and 7, 10.

Comparison measurement for L1

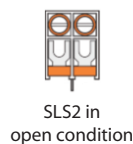
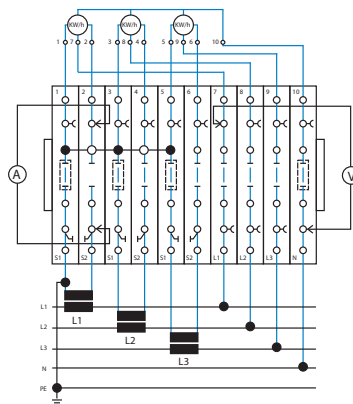

Sequence for test :

- 1) Remove SLS2 screw from terminal 2.
- 2) Connect ammeter to test sockets of terminal 2.
- 3) Open disconnect slide link of terminal 2.
- 4) Connect voltmeter to test sockets of terminals 7 and 10.

Meter exchange for L1

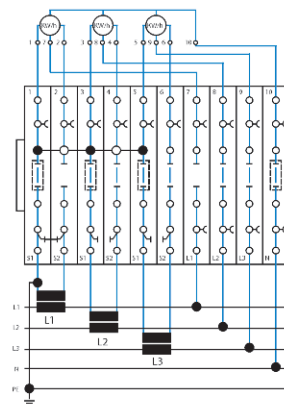

Sequence for test :

- 1) Close short circuit slide SLS2 of terminals 1 and 2.
- 2) Open disconnect slide link of terminal 2 and 7.
- 3) Disconnect meter for L1 at terminals 1, 2 and 7.

Glossary

Accuracy

The maximum deviation to be expected between a true meter reading and the actual value being measured under specified operating conditions. Usually indicated as percentage of full scale value for analog instruments or percentage of reading for digital instruments. (see figure 1)

Active energy

Active Energy is the product of Active Power and Time. The unit is Wh.

$$\text{Active Energy} = P * t \text{ [Wh]}$$

$$P = \text{active power [W]}$$

$$t = \text{time in hour [h]}$$

Active (Real or True) Power

It is measured in watts [W] and is the Power drawn by a electrical system.

Active Power

$$\text{Active Power } P = V * I * \cos \theta \text{ [W]}$$

$$V = \text{Voltage [V]}$$

$$I = \text{Current [A]}$$

$$\theta = \text{Power factor}$$

Ampere

Unit of electrical current. Amount of electrical current which flows through a 1 ohm resistor with 1 volt applied at a specific time.

Apparent Energy

Apparent Energy is the product of Apparent Power and Time. It's unit is VAh.

$$\text{Apparent energy} = S * t \text{ [VAh]}$$

$$S = \text{apparent power [VA]}$$

$$t = \text{time in hour [h]}$$

Apparent Power

It is measured in volt-amperes (VA) and is the voltage on an AC system multiplied by all the current that flows in it. It is the vector sum of the active and the reactive power.

$$\text{Apparent Power } S = V * I \text{ [VA]}$$

$$V = \text{Voltage [V]}$$

$$I = \text{Current [A]}$$

Average

Average value is normally taken to mean the average value of only half a cycle of the wave. (see figure 2)

Burden

The electrical load taken from an electrical circuit by measuring instruments expressed in Volt-Ampere (VA) or watts. In current transformers burden in VA is the maximum the transformer can support while operating within its rated accuracy.

Crest Factor

The ratio of peak voltage to the RMS voltage of a waveform (with the DC component removed).

CT (Current Transformer)

A current transformer (CT) is used to step down the large value of current. When current in a circuit is too high to directly apply to measuring instruments, a current transformer produces a reduced current proportional to the current in the circuit, which can be conveniently connected to measuring and recording instruments.

CT Ratio (Current Transformer Ratio)

CT ratio is the ratio of primary (input) current to secondary (output) current. A CT with a listed ratio of 4000:1 would provide 1A of output current, when the primary current was 4000A.

DC Shunt

A low-value resistor typically embedded in Ampere Meters. This low-value resistor "shunts" high currents around the Ampere Meters sensitive input circuit.

Export of energy

When energy accumulation is negative, it is defined as "Export of Energy".

Energy

It is Defined as the ability to do work & work is the transfer of Energy from one form to another.

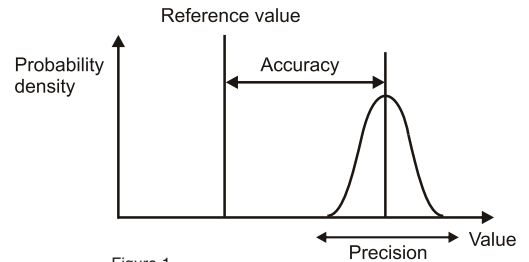
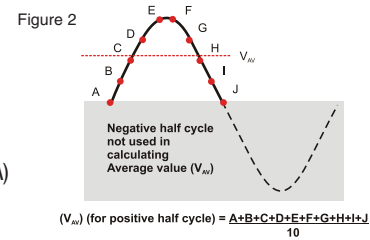

Figure 1

Figure 2



For a pure sine wave V_{av} will always be the PEAK value (V_m) x 0.637

End Scale Value

The end scale value of an instrument is the value of the actuating electrical quantity that corresponds to end scale indication. When zero is not at the end or at the electrical center of the scale, the higher value is taken.

Error

The difference between measured value, set value, or rated value, and the measured or supplied true value.

Frequency

Number of times an electrical signal replicates in one second; its unit is Hertz [Hz].

Frequency Output

An output in the form of frequency, which varies as a function of the applied input.

Frequency Response

A measure of how effectively a circuit or device transmits the different frequencies applied to it.

Full-Scale Input

The maximum value of an input voltage or current that can be safely applied to a digital panel meter.

Full-Scale Value

The arithmetic difference of the two end-scale values. When zero is not on the scale, the full-scale value is the higher end-scale value.

Impedance

The combination of resistance and reactance affecting the flow of an alternating current generally expressed in ohms.

Import of energy

When energy accumulation is positive it is defined as "Import of Energy".

Input Impedance

The resistance and reactance of a panel meter. In the case of a voltmeter, this impedance has to be taken into account when the source impedance is high.

Kwh

kWh stands for Kiliwatt- Hour, it is the energy consumed by 1000 Watts in 1Hour.

KVAh

kVAh stands for kilo-Volt-Ampere-hour known as Apparent Energy. It is the technical name for 'total' electrical energy, that includes both its 'useful' and the 'lossy' components. The unit of Apparent Energy is kVAh.

Lagging Power Factors

When load is capacitive the current waveform leads the voltage waveform. Capacitive reactances produce lagging power factor. Capacitive loads are capacitor banks or buried cables.

Leading Power Factors

When load is inductive the current waveform is lagging behind the voltage waveforms. Inductive reactances produce a leading power factor. Inductive loads are transformers, motors and wound coils.

LSD (Least Significant Digit)

The right-most active digit of a digital display.

Load

The amount of electrical power required by the connected electrical equipment.

Max Demand

It is the highest of demand values recorded .It is the highest value of power recorded within a particular interval. The Meter stores the reading only if it exceeds the previous maximum Demand value recorded.

MSD (Most Significant Digit)

The left-most digit on a digital display.

Nominal

The normal operating value.

Nominal Voltage

A nominal voltage value assigned to a circuit or system for the purpose of conveniently designating its voltage class.

Ohm

Unit of electrical resistance; one Volt can force one Ampere of current through a resistance of one Ohm.

Glossary

Output Load

The total effective resistance of the circuits and apparatus connected externally to the output terminals.

Over Voltage

A voltage greater than that at which a device or circuit is designed to operate.

Rated Overload

The maximum load over full scale value that an instrument can withstand without damage or failure. Displayed as a percentage of a full scale value.

Over Range

In digital meters, a reading that exceeds full scale (but is less than an overload) that does not require switching to a higher range.

Peak Voltage

The maximum value present in a varying or altering voltage. This value may be either positive or negative. This is known as the peak or crest value of an AC waveform. (see figure 3)

Peak to Peak Voltage

The total height between opposite peaks is known as peak to peak value of ac AC waveform. (see figure 4)

Phase Angle

The difference in degrees by which the voltage wave lags or leads the current wave in an AC circuit.

Power

Power is the rate at which energy is transferred, used, or transformed or Measure of the amount of work an electrical signal can do. The instantaneous electrical power P delivered to a component is given by $P(t) = I(t) * V(t)$.

Power Consumption

The power necessary to operate the meter.

Power Factor

It is the ratio between the KW and the KVA drawn by an electrical load. Where, the KW is the actual load power and the KVA is the apparent load power. It is a measure of how effectively electrical power is being used. Power Factor is usually expressed as a number between 0 and 1.

Power Supply

Separate unit or part of a circuit that supplies power to the rest of the circuit or to a system.

Pulse Output

In meters a pulse o/p corresponds to a pulse generated after a certain unit of energy is recorded by the meter which (Energy) intern is dependent on the product of CT & PT Ratio.

Range (Full Scale)

The difference between minimum and maximum values that an input or output can reach.

Ratio

The ratio of a current transformer indicates the multiple between the current in the secondary lines and the current in the primary lines. For example: a 50:5 transformer will transmit 5 Amperes through the secondary line when the primary line is carrying 50 Amperes.

Reactive Energy

Reactive energy is the product of power and time. Its unit is VARh.

$$\text{Reactive energy} = Q * t \text{ [VARh]}$$

$$Q = \text{reactive power [VAR]}$$

$$t = \text{time in hour [h]}$$

Reactive Power

It is measured in volt-amperes (VAR). Reactive Power is stored in and discharged by inductive motors, transformers and solenoids.

$$\text{Reactive power: } Q = V * I * \sin \theta \text{ [VARh]}$$

$$V = \text{Voltage [V]}$$

$$I = \text{Current [A]}$$

$$\theta = \text{Power factor}$$

Repeatability

The ability of an instrument to repeat its indications when the pointer is deflected upscale, compared to the indications taken when the pointer is deflected down-scale, expressed as a percentage of the fiducial value.

RMS

The RMS (Root Mean Square) value of a set of values (or a continuous time waveform) is the square root of arithmetic mean (Average) of the squares of the original values (or the function that defines the continuous waveform).

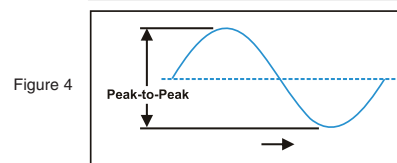
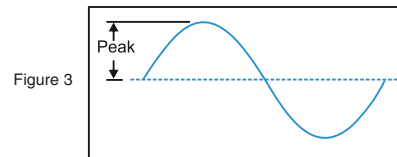

Sampling Rate

The sampling rate, sample rate, or sampling frequency (Fs) defines the number of samples per unit of time (usually seconds) taken from a continuous signal to make a discrete signal.

Scaling

For direct read out in engineering units, the capability of the meter to associate any desired value to the electrical input range.

Shunt

A calibrated low resistance connected in parallel with the input terminals of a voltmeter in order to enable measurements of large currents. It can be internal or external. The voltmeter measures the voltage drop typically in the milli volt range across the shunt resistor and displays a number corresponding to the current flowing through the shunt.

True RMS

'rms' stands for "root-mean-square". True RMS reading meters can accurately measure the value of non-sinusoidal waveforms (step, triangle, square, etc.). For significantly non-sinusoidal signals, a True RMS is required.

Volt

Unit of measurement of electrical potential. One volt applied across a one ohm resistor will produce a current of one ampere.

Voltage Burden

Burden voltage is the voltage drop caused by current (amps) flowing through a current measuring device. A large burden voltage can affect the circuit being measured, corrupting the measurement. For this reason, it is necessary for burden voltage to be kept as low as possible.

Volt Ampere

An AC unit of measure. Volt Amperes [VA] is the product a circuit's RMS voltage and its RMS current. The volt-ampere is also referred to as 'apparent power'.

Voltmeter

An instrument designed to measure and display, in either digital or analog format, AC or DC volts.

Watt

Unit of measurement of electrical power; one Watt is the amount of work that one Ampere at one Volt can do.

Wye

A three phase, four-wire electrical configuration where each of the individual phases is connected to a common point, the "center" of the Y. This common point normally is connected to an electrical ground.

Part No.	Page
MFM384-C-CU	6
MFM383A-CU	6
MFM374-CU	7
MFM374-C-CU	7
VAF36A-110V-CU	8
VAF39A-110V-CU	8
EM368-C-CU	9
MA12-110V-CU	10
MA12-50mV-DC-110V-CU	10
MA12-100mV-DC-110V-CU	10
MA501-110V-CU	11
MA2301-110V-CU	11
MV15-110V-CU	12
MV15-DC-20V-110V-CU	12
MV15-DC-200V-110V-CU	12
MV507-110V-CU	13
MV2307-110V-CU	13
MF16-110V-CU	14
MP14-110V-CU	14

TITLE - Title to the products of ALTECH shall remain with ALTECH until payment is made in full by Customer. Such reservation of title is for the purpose of securing the purchase price and shall not relieve Customer of the duty to inspect the products upon receipt, to notify ALTECH of any deficiencies or defects, and to exercise due care in the use, installation, operation, and maintenance of the products when on the premise of the Customer or under the control of the Customer. Notwithstanding any reservation of title by ALTECH, risk of loss shall pass to customer at any time of shipment.

SHIPMENT AND DELIVERY - All orders for destination in the mainland United States (less Hawaii, Alaska and non-continental United States possessions) will be shipped F.O.B. Flemington, N.J. All destination, shipping and other charges shall be paid by the Customer in accordance with ALTECH's then current shipping and billing practices.

Delivery dates given in the acceptance of any order are approximate. ALTECH shall not be liable for delays in delivery or in performance due to causes beyond its reasonable control including acts of God, acts of Customer, acts of civil or military authority, fires, strikes or other labor disturbances, war, riot or delays in transportation. In the event of such delay, the date of delivery or performance shall be extended for a period equal to the time lost by reason of the delay.

PRICE - PRICES in any ALTECH publication are subject to change without prior notification. Catalog prices are based on prices published in the current price list. All written quotations are valid for thirty (30) days from the date of quotation. Customer shall pay all sales, use, excise or similar taxes whenever ALTECH must itself pay and/or collect such tax from Customer arising out of the sale.

PAYMENT - Customer agrees to make payment within thirty (30) days of date of the invoice from ALTECH. Customer agrees to pay a late payment charge of one and one-half percent (1.5% per month, or the maximum late payment charge permitted by applicable law, whichever is less, on any unpaid amount for each calendar month (or fraction thereof) that such payment is in default. Orders amounting to less than \$100.00 will be billed at \$100.00 plus freight. Full carton purchases are required. In the event of referral to an attorney for collection, reasonable attorney's fees for collection of the overdue amount shall be paid by Customer. In the event payment is not received within 30 days from the date of invoice, any discount shall be cancelled and the full list price will be due.

LIMITED WARRANTY - ALTECH warrants to Customer that the equipment purchases shall be free from defects in material and workmanship under normal use and service for a period of one year from shipment.

Written notice as an explanation of the circumstances of any claim that the equipment has proved defective in material or workmanship shall be given promptly by the Customer to ALTECH.

ALTECH will not be liable for any misuse, improper operations, improper installation, improper maintenance, alteration, modification, accident or unusual degradation of the equipment or parts due to an unsuitable installation environment.

No representation of other affirmation of facts, including but not limited to statements regarding capacity, suitability for use or performance of the equipment, shall be or be deemed to be a warranty or representation by ALTECH for any purpose, nor give rise to any liability or obligation of ALTECH whatsoever.

Customer's sole and exclusive remedy in the event of breach of warranty, as set forth herein, is expressly limited to (1) the correction of the defect by adjustment, repair, modification, or replacement, or (2) issuance of a credit or refund of the purchase price for the defective equipment at ALTECH's election and sole expense.

EXCEPT AS SPECIFICALLY PROVIDED IN THIS AGREEMENT, THERE ARE NO OTHER WARRANTIES EXPRESSED OR IMPLIED INCLUDING BUT NOT LIMITED TO ANY IMPLIED WARRANTIES OR MERCHANTABILITY OR FITNESS FOR A PARTICULAR PURPOSE.

THIS WARRANTY EXTENDS ONLY TO THE CUSTOMER FROM ALTECH OR ITS AUTHORIZED DISTRIBUTOR.

LIMITATION OF LIABILITY - IN NO EVENT, SHALL ALTECH BE LIABLE FOR LOSS OF PROFITS, INDIRECT, SPECIAL, CONSEQUENTIAL OR OTHER SIMILAR DAMAGES ARISING OUT OF ANY BREACH OF THIS AGREEMENT OR OBLIGATIONS UNDER THE AGREEMENT.

ALTECH SHALL NOT BE LIABLE FOR ANY DAMAGES CAUSED BY DELAY IN SHIPMENT, INSTALLATION OR FURNISHING OF EQUIPMENT OR SERVICES UNDER THIS AGREEMENT.

No action arising out of any claimed breach of this Agreement may be brought by either party more than two (2) years after the cause of action has accrued.

PATENT INDEMNITY - ALTECH shall defend or settle any suit or proceeding brought against Customer based on a claim that any equipment made to ALTECH design and furnished hereunder constitutes an infringement of any existing United States patent, provided (ALTECH) is notified promptly in writing and is given complete authorization and information required for the defense, and ALTECH shall pay all damages and costs awarded against Customer, but shall not be responsible for any costs, expense or compromise incurred or made by Customer without ALTECH's prior written consent. If any equipment is in ALTECH's opinion likely to or does become the subject of a claim for patent infringement, ALTECH may at its option and expense procure for Customer the right to continue using the device, modify it to become non-infringing, but in the event ALTECH is not reasonably able to modify, substitute, or otherwise procure for Customer the right to continue using it, ALTECH will remove such equipment and refund to Customer the amount paid in excess of a reasonable rental for past use.

ALTECH shall not be liable for any infringement or claim based upon use of the equipment in combination with other equipment not supplied by ALTECH or with modifications made by Customer.

The foregoing states the entire liability of ALTECH to Customer arising from patent infringement.

SELLER'S REMEDIES - Should Customer fail to make any payment within ten (10) days of its due date, or fail to perform any other of the Customer's obligation hereunder upon thirty (30) days written notice, or should Customer be or become insolvent or be a party to any bankruptcy receivership proceeding prior to full payment of all amounts payable hereunder, ALTECH may: (a) with or without demand or notice to customer declare the entire amount unpaid immediately due and payable; (b) enter upon the premises where the equipment may be found and remove it (Customer shall assemble the equipment and make it available to ALTECH at a place reasonably convenient to both parties and shall permit and assist ALTECH in effecting the retaking and removal of the equipment); and (c) sell any or all the equipment as permitted under applicable law, applying the proceeds of the sale to payment of the expenses of retaking, repairing and selling the equipment, reasonable attorney fees and to the satisfaction of all indebtedness then due and unpaid under this Agreement. Any surplus shall be paid to Customer and any deficiency shall be paid to ALTECH by Customer.

The remedies provided herein shall be cumulative and in addition to all other remedies provided by law or equity or under the Uniform Commercial Code.

GOVERNING LAW - This agreement will be governed by the Laws of the State of New Jersey.

GENERAL - This Agreement shall only become effective and binding when either (a) it has been accepted and executed by an authorized representative of ALTECH, or (b) the equipment has been shipped to Customer, with or without acceptance in writing hereon. Notice of acceptance is hereby waived by Customer. Customer hereby acknowledges receipt of a true and complete copy hereof.

No addition to or modification of any of the Terms and Conditions of Sale as they appear herein shall be binding upon ALTECH unless signed in writing by duly authorized representative of ALTECH in Flemington, N.J.

Typographical and clerical errors in quotations, orders and acknowledgments are subject to correction.

This Agreement is not assignable without the prior written consent of ALTECH. Any attempt to assign any of the rights, duties or obligations of this Agreement without such consent is void.

If any provision or provisions of this Agreement shall be held to be invalid, illegal or unenforceable, the validity, legality and enforceability, of the remaining provisions shall not in any way be affected or impaired thereby.

ALTECH is not responsible for failure to fulfill its obligation under this Agreement due to causes beyond its control, or except as agreed herein.

THE CUSTOMER ACKNOWLEDGES THAT HE HAS READ THE AGREEMENT, UNDERSTANDS IT, AND AGREES TO BE BOUND BY ITS TERMS AND CONDITIONS. FURTHERMORE, THE CUSTOMER AGREES THAT IT IS THE COMPLETE AND EXCLUSIVE STATEMENT OF THE AGREEMENT BETWEEN THE PARTIES, WHICH SUPERSEDES ALL PROPOSALS OR PRIOR AGREEMENTS, ORAL OR WRITTEN, EXPRESSED OR IMPLIED, AND ALL OTHER COMMUNICATIONS BETWEEN THE PARTIES RELATING TO THE SUBJECT MATTER OF THIS AGREEMENT.



Altech Search

Altech® Online Store

Home | Stock Check | Distributors | Information | News | Contact | Rep/Dial Logs | Altech Mexico

WEB TOOLS

- Product Catalogs
- Request for Quote
- Sample Request
- Catalog Request

PRODUCT MENU

- Circuit Protection / Control >
- Connectors >
- Enclosures >
- European Spare Parts >
- Foot Switches
- Interface Modules >
- Power Supplies
- Push Buttons & Pilot Lights >
- Relays >
- Sensors >
- Terminal Blocks >
- Timer Lights
- Wire & Cable Management >
- Home

New Products and Promotions

Serving the Automation & Control Industry Since 1984

Circuit Protection

 Circuit Protection Devices	 Busbar and Power Distribution	 Contactors, Overload Relays, Manual Motor Starters	 Motor Disconnect Switches	 European Fuses
--	---	--	---	--

Connectors

 Industrial Rectangular Connectors	 Pin & Sleeve Devices	 Receptacles	 Foot Switches	 Sensors
---	--	---	---	---

Enclosures

 Industrial Enclosures	 DIN Enclosures	 Interface Modules	 Safety Relays	 Voltage Relays
--	---	--	--	---

Modules & Relays

Power Supplies

 Power Supplies	 22 & 30 mm Push Buttons	 DIN Rail	 Wire & Cable Management
--	---	--	---

Push Buttons

DIN Rail

Wire & Cable Management

Terminal Blocks

 Din Rail Terminal Blocks	 Panel Mount Terminal Blocks	 Printed Circuit Board Terminal Blocks	 Eurostrips	 Distribution Blocks
--	---	---	--	---

Miscellaneous

 Females	 Custom Assembly	 Marking & Engraving Systems	 Power Semi-conductors	 European Spare Parts
---	---	---	---	--

Altech Corporation
35 Royal Road
Flemington, NJ 08822-6000
P 908.806.9400 • F 908.806.9490
www.altechcorp.com

