

Float switch

Series Standard-Float switch

Description **MAE-733 KR1,5S 0360**

Article number **6835188003**

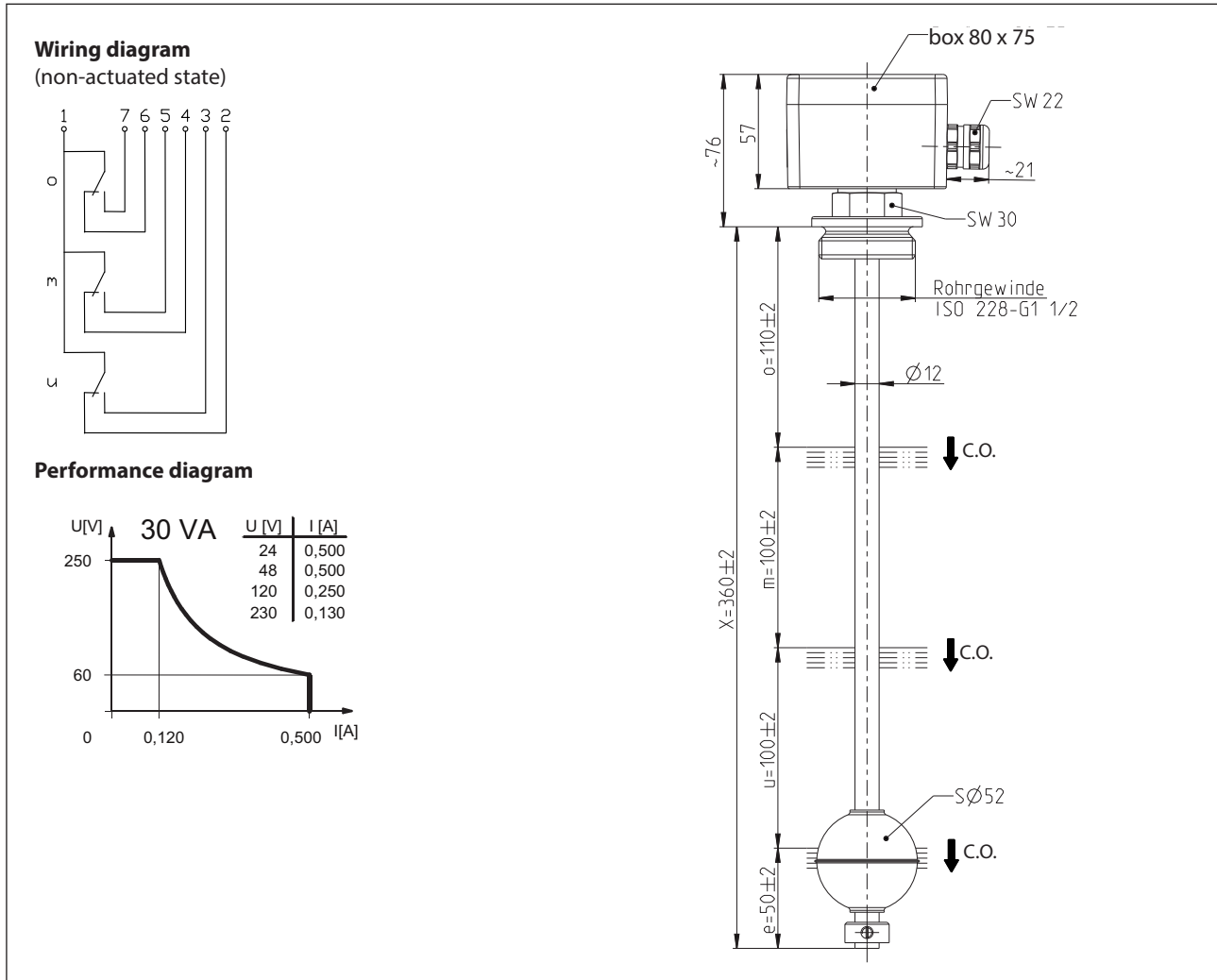

Characteristic features in accordance with EN 60947-5-1

Electrical data	
max. switching voltage	250 V
max. switching current	0,5 A
max. switching capacity	30 VA
mechanical life	10 ⁷ to 10 ⁹ switches depending on the load
Switching element	3 x C.O., falling level
Protection class	I

Mechanical data	
Housing material	Aluminium coated with RAL 7001
Cable gland material	brass, nickel plated
Switching tube material	X6CrNiMoTi17-12-2 (1.4571)
Float material	X6CrNiMoTi 17-12-2 (1.4571)
- density	about 0,65 g/cm ³ ±10 %
- depth of immersion	32 mm ± 2 mm (to a fluid-density of 1 g/cm ³)
Adjusting ring material	X6CrNiMoTi17-12-2 (1.4571)
Gasket material	Klingersil and LSR
Ambient air temperature	-5 °C to +100 °C
Liquid temperature	-5 °C to +100 °C
Connection	Connecting block inside the terminal box Cable gland with sealing range 9,5 - 6,5 mm
Protection type	IP 65 acc to IEC529 / EN 60529
Max. pressure	10 bar

EU Conformity
acc. to directive 2006/95/EC

General details
<p>Repeatability of switching points is ±0,05 mm based on the same geometrical conditions as of a switch device. The measures of the switching points refer to a fluid-density of 1 g/cm³. The tolerance of the switching points is ±2 mm Pay attention to the contact protection, when switching inductive or capacitive loads. Maximum data must not be exceeded!</p>

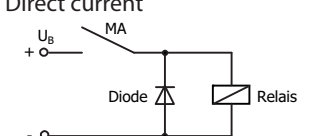
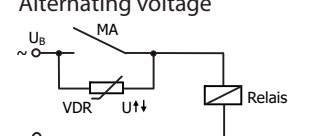
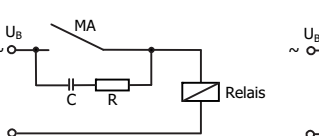
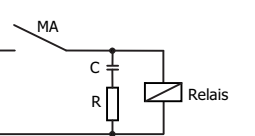
Inductive loads
<div style="display: flex; justify-content: space-around;"> <div style="text-align: center;"> <p>Direct current</p>  <p>Suppression of voltage peaks with a free-wheeling diode</p> </div> <div style="text-align: center;"> <p>Alternating voltage</p>  <p>Suppression of voltage peaks with a VDR</p> </div> <div style="text-align: center;">  <p>Suppression of voltage peaks with an RC element</p> </div> <div style="text-align: center;">  </div> </div>

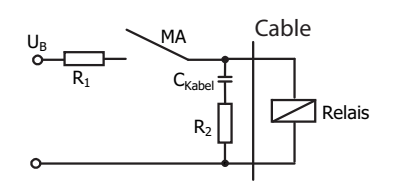
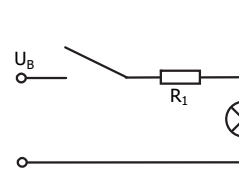
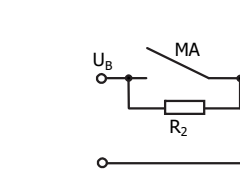
Capacitive loads and lamp loads
<div style="display: flex; justify-content: space-around;"> <div style="text-align: center;">  <p>Contact protection with resistors for limiting current</p> </div> <div style="text-align: center;">  </div> <div style="text-align: center;">  </div> </div>