

Technical Data

Float Switch

Standard float switches

Description **MAI-723 LYS 0410**

Article number **6826370002**

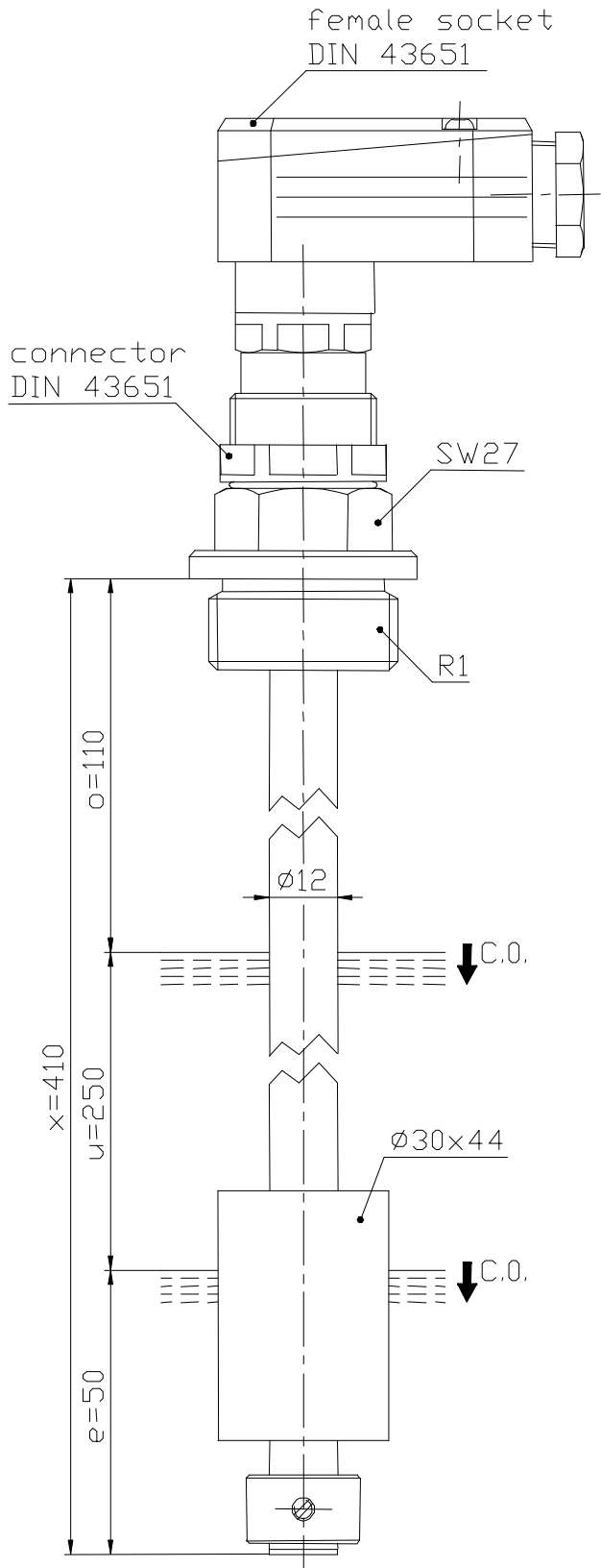

Performance diagram (maximum data)

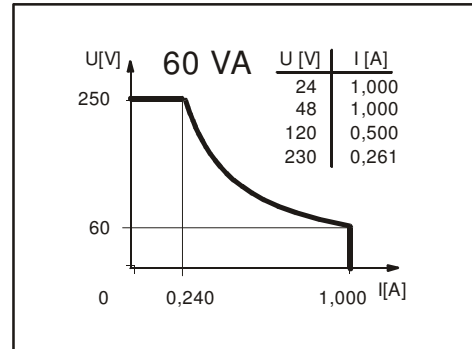

Wiring diagram (matching to the drawing)

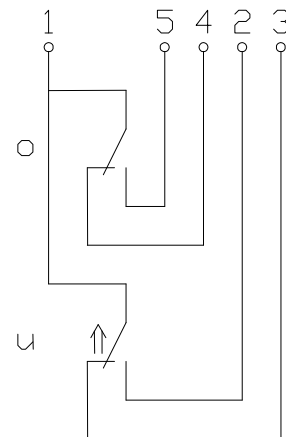

Subject to change without notice.

Standard float switches

Description **MAI-723 LYS 0410** Article number **6826370002**

Electrical data

Reed contact	max. switching voltage	250 V
	max. switching current	1,0 A
	max. switching capacity	60 VA
	mechanical life	10 ⁷ to 10 ⁹ switches depending on the load
Switching element		2 change over contact, falling level
Direction category		AC-22A and DC-22A acc to DIN VDE 0660 T107
Standard		acc to DIN VDE 0660 T200

Mechanical data

Screw connection material	PVC	
Switching tube material	PVC	
Float material	PP	
	-density	about 0,62 g/cm ³ ±10%
	-depth of immersion	30 mm ±2 mm (to a fluid-density of 1 g/cm ³)
Adjusting ring material	PVC	
Ambient air temperature	-5°C to +60°C	
Liquid temperature	-5°C to +60°C	
Connection	plug in connection acc. to DIN 43651	
Protection type	IP 65 acc to DIN VDE 0470 T1 <u>only with female socket</u>	
Max. pressure	5 bar	

General details

Repeatability of switching points is ±0,05mm based on the same geometrical conditions as of a switch device.

The measures of the switching points refer to a fluid-density of 1 g/cm³.

The tolerance of the switching points is ±2mm

Pay attention to the contact protection, when switching inductive loads. Maximum data must not be exceeded!