

Foot-switch Series F1

Description **F1-SU1ZCA2ZDR**

Article number **6161500794**

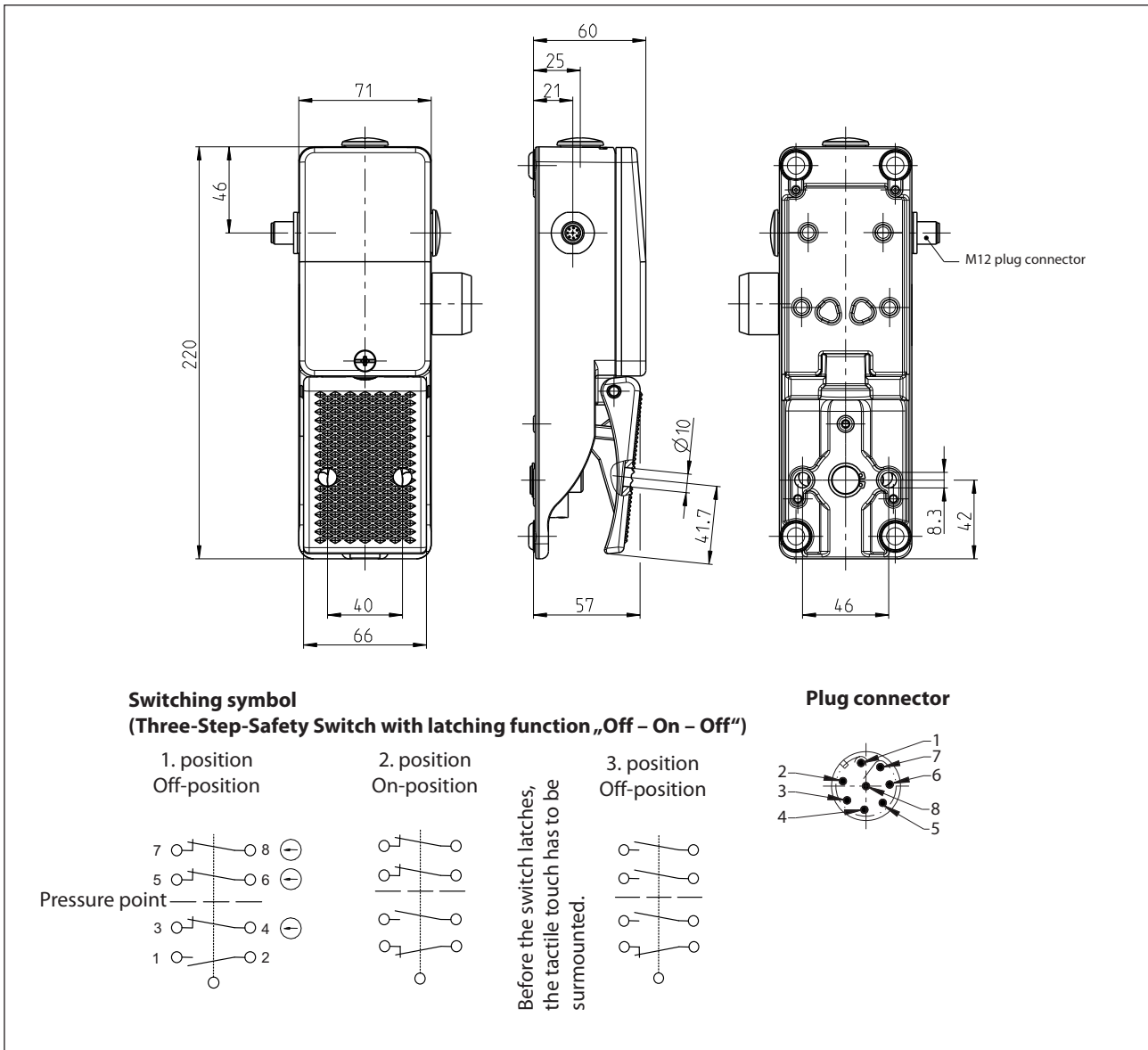

Electrical Data	
Rated operational voltage	U_e 30 V
Utilization category	AC-15, U_e / I_e 30 V AC / 1,5 A
Direct opening action	\odot acc. to IEC/EN 60947-5-1, annex K (pedal stop)
Short-circuit protective device	Fuse 2 A gG
Protection class	III, safety extra-low voltage

