

Safety switch - Ex II 2 D
Series SI2

Description **SI2-U2Z AK EXD**

Article number **6091288024**

Operating symbol

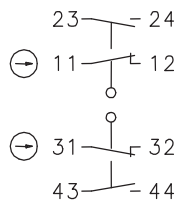

Operating diagram

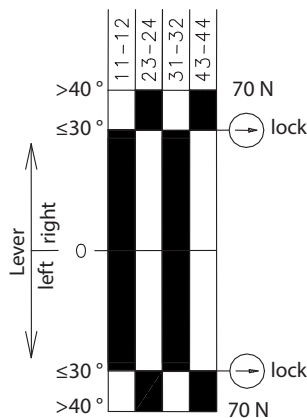

Tolerance:
Operating point $\pm 3,5^\circ$
Operating torque $\pm 10\%$
Latching according to DIN EN ISO 13850

On Off

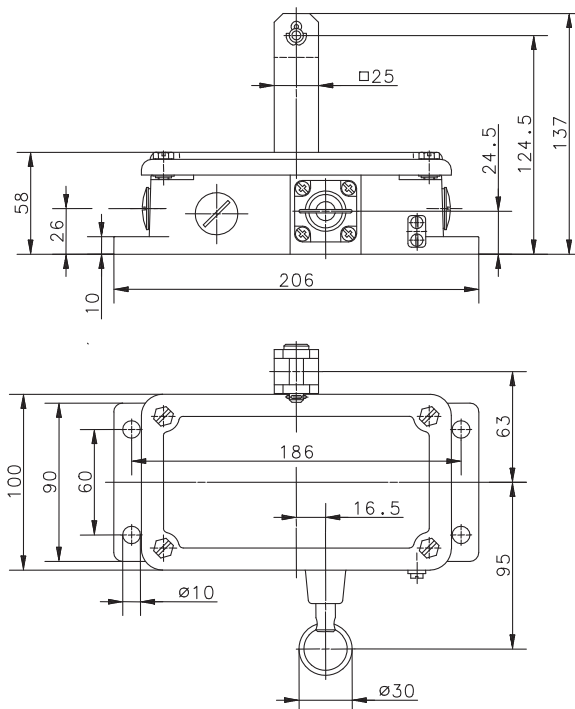

Electrical Data

Rated insulation voltage	U_i	400 V AC
Conv. thermal current	I_{the}	10 A
Rated operational voltage	U_e	240 V
Utilization category		AC-15, U_e/I_e 240 V / 3 A
Positive opening NC contact	\ominus	acc. to IEC/EN 60947-5-1, Annex K
Short-circuit protective device		Fuse 10 A gG
Protection class		I

Mechanical data	
Enclosure	Gray iron
Cover	Gray iron
Actuator	Lever (St)
Ambient air temperature	-20 °C bis +60 °C
Maximum surface temperature	80 °C
Contact type	2 NC, 2 NO (Zb)
Reset facility	Rotate pulling the key-ring ($\geq 50N$)
Mechanical life	2 x 10 ⁶ operating cycles
Switching frequency	$\leq 10 / \text{min.}$
Assembly	4 x M8
Connection	8 screw terminals (M3,5)
PE-termination	1x M4
Conductor cross-sections	Solid: 0,5 ... 1,5 mm ² Litz wire with ferrules: 0,5 ... 1,5 mm ²
Cable entrance	3 x M20 x 1,5
Weight	$\approx 3,8 \text{ kg}$
Installation position	operator definable
Protection type	IP65 acc. to IEC/EN 60529

Standards	
	VDE 0660 T100, DIN EN 60947-1, IEC 60947-1
	VDE 0660 T200, DIN EN 60947-5-1, IEC 60947-5-1
	EN 60079-0, EN 60079-31

Test Certificate	
	IBExU 13 ATEX 1115

Explosion Protection	
	 II 2 D Ex tb IIIC T80°C Db

EU Conformity	
	acc. to directive 2014/34/EU

Approvals	
	cCSA _{US} A300
	UL

Notes	
<p>The switching unit must be securely installed.</p> <p>The switch may not be used as a mechanical stop.</p> <p>The metal enclosure of the switch must be earthed if the enclosure can be expected to develop a hazardous charge during operation.</p> <p>The degree of protection specified (IP code) applies only to a properly closed cover and the use of an equivalent cable gland with adequate cable.</p> <p>Cable and cable gland must fulfil the safety requirements according to the regulations of intended applications in areas with explosive risks.</p>	