

Foot-switch Series MF1

Description **MF1-A500-L-0**

Article number **6060100018**

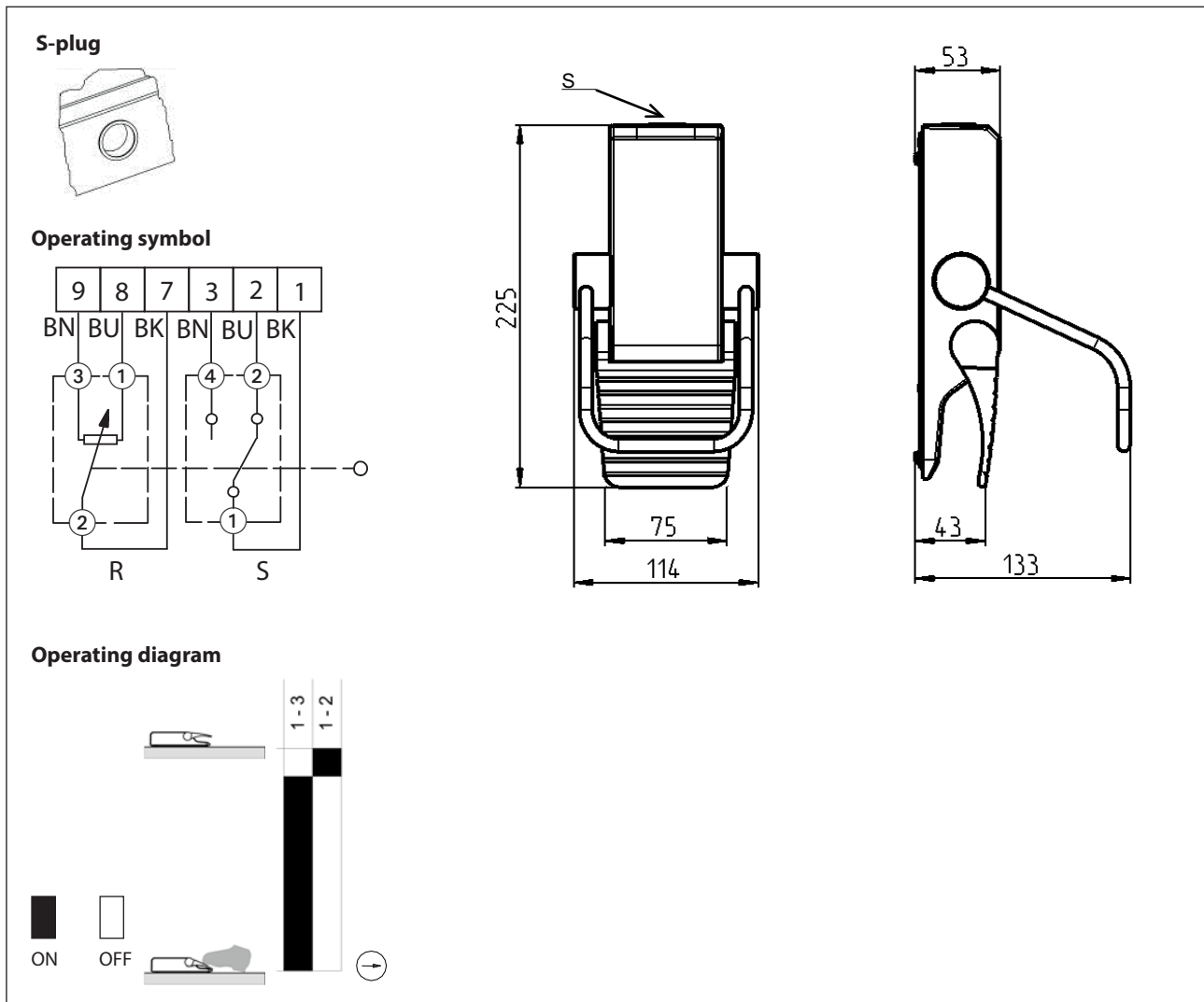

Electrical data	Microswitch	Potentiometer
Rated current	0,5 A	-
Contact current	-	≤ 0,3 mA
Rated operating voltage	30 V DC	30 V DC
Ferrule resistor	-	10 KΩ ±10%
Max. wiper current in case of malfunction	-	100 mA
Power rating	-	max. 2 W/70°C
Protection class	I (based on foot-switch complete)	

Mechanical data	
Enclosure	AL, die-cast (powder-coated), Pantone Cool Gray 2c
Cover	AL, die-cast (powder-coated), Pantone Cool Gray 2c
Actuator	1 pedal (thermoplastic) RAL7036
Ambient air temperature @ $t = \infty$	$-10\text{ °C} \leq T \leq +80\text{ °C}$
$t \leq 2\text{ h}$ (cleaning)	$-10\text{ °C} \leq T \leq +95\text{ °C}$
Normal use condition	temperature $+10\text{ °C} \leq T \leq +40\text{ °C}$ air humidity 5 % ... 95 % - no condensation atmospheric pressure 700 hPa ... 1060 hPa
Storage and transport condition	temperature $-20\text{ °C} \leq T \leq +80\text{ °C}$ air humidity 5 % ... 95 % - no condensation atmospheric pressure 700 hPa ... 1060 hPa
Contact type	Potentiometer with microswitch (changeover contact)
Operating force	$15\text{ N} \pm 10\%$
Mechanical life	50000 rotation cycles of the potentiometer
Switching frequency	≤ 20 operating cycles/min
Connection	6 connections (screw terminals M2)
Conductor cross-sections	Solid: $\leq 1,5\text{ mm}^2$ Litz wire with or without ferrules: $\leq 1\text{ mm}^2$
Protection ground	2 x M4
Cable entrance	1 x M20 x 1,5
Weight	$\approx 1,3\text{ kg}$
Protection type	IPX8 acc. to IEC/EN 60529 (0,15 bar / 1 h)

Standards
VDE 0660 T100, DIN EN 60947-1, IEC 60947-1
VDE 0660 T200, DIN EN 60947-5-1, IEC 60947-5-1
IEC 60601-1
UL 60601-1

EU Conformity
acc. to directive 2006/42/EC

Approvals
Only if approved components are used 

Test
AP

Notes
The specified protection classification (IP code) applies only when the cover is closed and the use of an equivalent cable gland with adequate cable. Selection of components and installation of the grounding equipment conductor must fulfil IEC 60601-1 / UL 60601-1 requirements.