

REVISIONS FOR DWG # APx

| REV | CH.NO. | DESCRIPTION | DATE | REVISED BY |
|-----|--------|-----------------|----------|------------|
| - | - | ORIGINAL DESIGN | 07/26/16 | ARON G |

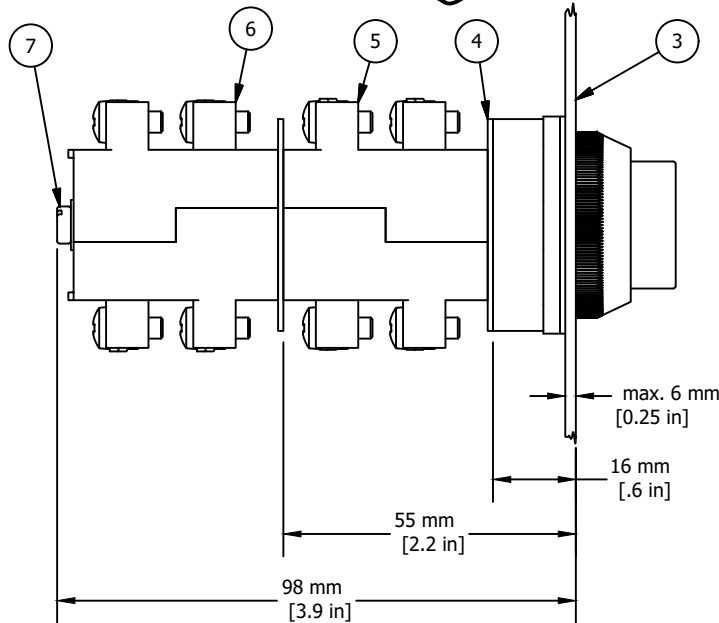
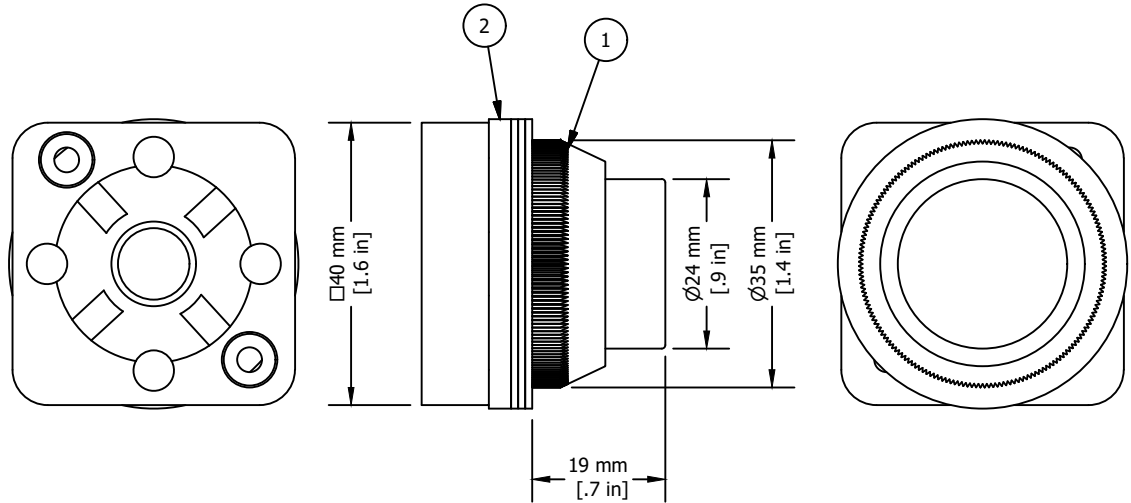
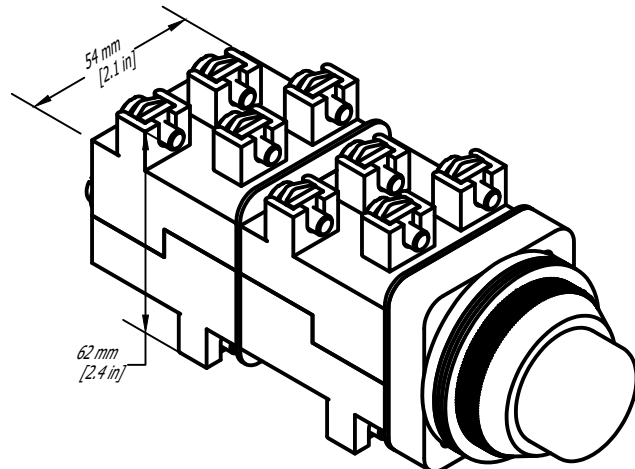

* = Operator includes 3x ARW1.2 and 1x ARW3.2
 ** = Switch Contacts include Contact element washer and two SC24 installation screws, if more than two contact blocks are used, additional screws must be purchased separately (SC45, SC65 or SC90)

| ITEM | DESCRIPTION | CAT. NO. | COLOR | MIN. QTY. | MAX. QTY. | | |
|------|---|---------------------|---------------|---------------|-----------|---|---|
| 1* | 30 mm Projecting Non-Illuminated Momentary Metal Operator | AP1 | White | 1 | 1 | | |
| | | AP2 | Black | 1 | 1 | | |
| | | AP3 | Green | 1 | 1 | | |
| | | AP4 | Red | 1 | 1 | | |
| | | AP6 | Blue | 1 | 1 | | |
| | | AP8 | Yellow | 1 | 1 | | |
| | | 2* | Rubber washer | ARW1.2/ARW3.2 | Black | 1 | 4 |
| | | 3 | Panel | - | - | - | - |
| 4** | Contact Element washer | - | Black | 1 | 2 | | |
| 5** | Switch Contacts | S11 | Red | 1 | 2 | | |
| 6** | Switch Contacts | S12 | Yellow | 1 | 2 | | |
| 7** | Contact Block Installation Screws | SC25/SC45/SC65/SC90 | - | 2 | 2 | | |

UNLESS OTHERWISE SPECIFIED
 • ALL DIMENSIONS ARE IN MILLIMETERS
 • THIRD ANGLE PROJECTION

| • TOLERANCE | |
|-------------|-----------|
| XX | ± 1.00 mm |
| XX.X | ± 0.50 mm |
| XX.XX | ± 0.20 mm |
| ALL | ± XX mm |

C-THINK

This Drawing is the property of
Altech Corp.
 35 Royal Road
 Flemington NJ 08822-6000
 (908) 806-9400 • Fax (908) 806-9490

AND IS A CONFIDENTIAL DISCLOSURE LENT WITHOUT CONSIDERATION OTHER THAN THE BORROWER'S AGREEMENT THAT IT SHALL NOT BE REPRODUCED, COPIED, LENT, OR DISPOSED OF DIRECTLY OR INDIRECTLY NOR USED FOR ANY PURPOSE OTHER THAN THAT FOR WHICH IT IS SPECIFICALLY FURNISHED.

TITLE: 30mm Non-Illuminated Metal Operators Projecting Momentary

| | | | | | |
|-----------------------------|----------|--------------|---------------|--------|---------|
| DRAWN BY: Aron Gyorgypal | 07/26/16 | DRAWING NO.: | M-Cad-1PB-APx | REV.: | - |
| CHECKED BY: Laszlo G | 07/26/16 | SCALE: | - | SHEET: | 1 OF: 1 |
| RELEASED BY: Laszlo G | 07/26/16 | | | | |